



**Tradias Issuance GmbH**

(a limited liability company incorporated under the laws of the Federal Republic of Germany,  
having its corporate domicile in Frankfurt am Main, Federal Republic of Germany)

as Issuer

**Programme for the issuance of tokenized securities  
(the "Programme")**

Under the Programme, Tradias Issuance GmbH (the "**Issuer**") may from time to time issue securities in tokenized form secured by a lien on the hedging account (the "**Tokenized Securities**"). The Tokenized Securities do not have a fixed maturity date. The Tokenized Securities will be governed by the laws of the Federal Republic of Germany ("**Germany**").

This document constitutes a base prospectus within the meaning of Article 8(1) of Regulation (EU) 2017/1129 of the European Parliament and of the Council of 14 June 2017 (the "**Prospectus Regulation**") of Tradias Issuance GmbH (the "**Base Prospectus**"). This Base Prospectus will be published in electronic form together with all documents incorporated by reference on the website of the Issuer ([www.tradias.de](http://www.tradias.de)).

This Base Prospectus has been approved by the *Bundesanstalt für Finanzdienstleistungsaufsicht* ("**BaFin**") in its capacity as competent authority under the Prospectus Regulation.

BaFin only approves this Base Prospectus as meeting the standards of completeness, comprehensibility and consistency imposed by the Prospectus Regulation. Such approval should not be considered as an endorsement of the Issuer that is the subject of this Base Prospectus. Further, such approval should not be considered as an endorsement of the quality of the Tokenized Securities that are the subject of this Base Prospectus. Investors should make their own assessment as to the suitability of investing in the Tokenized Securities.

The Tokenized Securities have not been, and will not be, registered under the U.S. Securities Act of 1933, as amended, (the "**Securities Act**"). The Tokenized Securities are being offered outside the United States of America (the "**United States**" or "**U.S.**") in accordance with Regulation S under the Securities Act, and may not be offered, sold or delivered within the United States except pursuant to an exemption from, or in a transaction not subject to, the registration requirements of the Securities Act.

**This Base Prospectus may not be used for the purposes of an offer or solicitation by anyone in any jurisdiction in which such offer or solicitation is not authorised, or to any person to whom it is unlawful to make such offer or solicitation.**

**On 10 January 2023, the Issuer published a base prospectus for the issuance of tokenized securities. This Base Prospectus succeeds such base prospectus dated 10 January 2023.**

**The validity of this Base Prospectus will expire at the end of 30 April 2025. Any obligation to supplement a base prospectus in the event of significant new factors, material mistakes or material inaccuracies does not apply when a base prospectus is no longer valid.**

1.	GENERAL DESCRIPTION OF THE PROGRAMME.....	2
1.1	General.....	2
1.2	Issue Price and Yield.....	2
1.3	Purchase of Tokenized Securities .....	2
1.4	Reason for the Offers .....	2
1.5	Listing and Admission to Trading.....	2
1.6	Rating.....	2
2.	RISK FACTORS .....	3
2.1	Risks relating to the Issuer .....	3
2.2	Risks relating to the Tokenized Securities .....	4
3.	IMPORTANT NOTICE .....	9
4.	RESPONSIBILITY STATEMENT .....	10
5.	CONSENT TO THE USE OF THE BASE PROSPECTUS .....	11
6.	LISTING AND TRADING.....	12
7.	REASONS FOR THE OFFER AND USE OF PROCEEDS .....	13
8.	NOTIFICATION.....	14
9.	AUTHORISATION .....	15
10.	GENERAL INFORMATION ABOUT THE ISSUER .....	16
10.1	General Information.....	16
10.2	Corporate Purpose.....	16
10.3	Principal Activities and expected financing of the issuer .....	16
10.4	Organisational Structure .....	17
10.5	Management Board.....	18
10.6	Share Capital.....	18
10.7	Fiscal Year .....	18
10.8	Rating.....	18
10.9	Major Shareholders .....	18
10.10	Interests of Natural and Legal Persons involved in the Issue/Offer.....	19
10.11	Material Contracts and Transactions.....	19
10.12	Trend Information .....	19
10.13	Material Adverse Change in the Prospects .....	19
10.14	Significant Change in the Financial Performance.....	20
10.15	Significant Change in the Financial Position .....	20
10.16	Borrowing and Funding .....	20
10.17	Legal and Arbitration Proceedings.....	20
11.	HISTORICAL FINANCIAL INFORMATION.....	21
12.	GENERAL DESCRIPTION OF THE TOKENIZED SECURITIES AND THE PROGRAMME .....	22
12.1	Description of the Tokenized Securities .....	22
12.2	Description of the Security.....	25
13.	TERMS AND CONDITIONS.....	27
14.	FORM OF FINAL TERMS.....	45
15.	TAXATION .....	50
16.	SUBSCRIPTION, SALE AND OFFER OF THE TOKENIZED SECURITIES.....	51
16.1	Offer of the Tokenized Securities .....	51
16.2	Selling Restrictions .....	53
17.	GENERAL INFORMATION .....	57
17.1	Incorporation by Reference.....	57
17.2	Documents on Display .....	58
18.	NAMES AND ADDRESSES.....	59

## 1. GENERAL DESCRIPTION OF THE PROGRAMME

### 1.1 GENERAL

Under this Base Prospectus, Tradius Issuance GmbH (the "**Issuer**") may, from time to time, issue Tokenized Securities denominated in euro. The total up to amount of a specific issue of Tokenized Securities will be set out in the relevant final terms document (the "**Final Terms**", substantially in the form set out below under "14. FORM OF FINAL TERMS") prepared in relation to each issue of Tokenized Securities under the Programme. Each issue of Tokenized Securities (each a "**Series of Tokenized Securities**") will be tokenized.

Each Series of Tokenized Securities issued under this Base Prospectus will track the value of a (public) investment fund (in each case, as specified in the Final Terms, the "**Underlying**") managed by a investment management company (*Kapitalverwaltungsgesellschaft*). The Tokenized Securities do not have a fixed maturity date.

Tokenholders have the right to request redemption of the Tokenized Securities, at any time, in cash or through delivery of units of the Underlying.

The Issuer will create a hedging position (the "**Hedging Position**") in which each Tokenized Security is represented by a unit of the Underlying. If the delivery of the unit of the Underlying is delayed beyond the usual settlement period, the Issuer will use cash or other assets, including derivatives, to ensure that the Hedging Position covers the whole amount of the Tokenized Securities issued. The assets of the Hedging Position will be held in a securities account and a cash account (together, the "**Hedging Account**") which will be secured with a lien (*Pfandrecht*) for the benefit of the Tokenholders.

### 1.2 ISSUE PRICE AND YIELD

The issue price of the relevant Series of Tokenized Securities will be specified in the relevant Final Terms.

The yield of the Tokenized Securities cannot be calculated at the issue date of a Series of Tokenized Securities.

### 1.3 PURCHASE OF TOKENIZED SECURITIES

In the primary market, each issue of a Series of Tokenized Securities is initially only purchased by Authorised Participants and may subsequently be offered by financial intermediaries to institutional and retail investors, in compliance with applicable selling restrictions during the relevant offer period (as specified in the relevant Final Terms) also with regard to specific offering jurisdictions. As a consequence, only Authorised Participants may buy Tokenized Securities directly from the Issuer in the primary market. Investors will not be able to buy Tokenized Securities directly from the Issuer in the primary market but may only buy Tokenized Securities from financial intermediaries.

### 1.4 REASON FOR THE OFFERS

Unless specified otherwise in the relevant Final Terms, the reason for the issue of Tokenized Securities under the Programme is primarily to finance the general business development of the Issuer.

### 1.5 LISTING AND ADMISSION TO TRADING

The Tokenized Securities will not be admitted to trading on any stock exchange. The Tokenized Securities issued under this Programme will not be admitted to trading on any stock exchange at all. The Tokens may be admitted to trading on a DLT MTF subject to Regulation (EU) 2022/858 of the European Parliament and of the Council of 30 May 2022 on a pilot regime for market infrastructures based on distributed ledger technology, and amending Regulations (EU) No 600/2014 and (EU) No 909/2014 and Directive 2014/65/EU.

### 1.6 RATING

Neither the Issuer nor any Series of Tokenized Securities are rated.

## 2. RISK FACTORS

*The Issuer believes that the following factors may affect its ability to fulfil its obligations under the Tokenized Securities.*

*The risk factors are presented in a limited number of categories depending on their nature. In each category the two most material risk factors are mentioned first according to the assessment of the Issuer. The Issuer assesses the materiality of the risk factors based on the probability of their occurrence and the expected magnitude of their negative impact.*

### 2.1 RISKS RELATING TO THE ISSUER

The following descriptions of the risk factors relating to the Issuer and their occurrence within a risk category, with the two most material risk factor presented first in each category, should be understood as descriptions of residual risks, i.e. of the remaining risks following all counter measures taken in order to avoid such risks or limit their adverse effects.

#### a) Risks related to the Issuer's business activities

***Risks related to the limited business objective of the Issuer.***

The focus of the Issuer's business activities is the issuance of tokenized securities linked to underlyings in the form of shares of investment funds issued by a investment management company. The Issuer will not carry out any other business than the issue of securities which are linked to different types of underlyings. Because of this limited business objective, the Issuer is exposed to the risk that the underlyings do not become successful or become less successful going forward and the Issuer cannot adapt to such changed circumstances. Due to this limited business objective the Issuer may then be unsuccessful in carrying out its business which could have an adverse impact on the Issuer's business and financial situation.

***The Issuer does not have a long and comprehensive track record.***

The Issuer was registered with the commercial register of the local court (*Amtsgericht*) of Frankfurt am Main, Germany on 18 November 2021. Due to such a short period of existence, the Issuer does not have a long and comprehensive track record of successfully operating the business activity described herein. On 22 October 2023, the Issuer has issued securities in the amount of approximately EUR 800,000 and has carried out limited other business activities since. Hence, there is a risk that the Issuer will not be successful in issuing the Tokenized Securities, and that the Issuer will not make profits, despite this being the Issuer's aim. If the Issuer becomes unsuccessful in the issuance of securities, the Issuer may cease its business activities as issuer or ultimately become insolvent. Although, the Issuer takes reasonable efforts to develop its business, there can be no assurance that the planned business activities will be successful in the future which could have an adverse impact on the Issuer's business and financial situation.

***Reputation.***

The Issuer depends on its reputation and the reputation of associated parties (i.e. parties who the Issuer conducts business with, such as Bankhaus Scheich Wertpapierspezialist AG, Société Générale S.A., Zweigniederlassung Frankfurt and Cashlink Technologies GmbH (among others)) to maintain and grow its core business. Any material adverse event could impact the Issuer's reputation, which could, in turn, depress the Issuer's profitability, creditworthiness and fundraising capacity. This, in turn, can affect the demand for and liquidity of any Series of Tokenized Securities and price of any Series of Tokenized Securities on the market related to the prices of the relevant underlyings and – in case such development triggers an Issuer Call Redemption Event in relation to a Series of Tokenized Securities – may result in the Issuer giving an Issuer Call Redemption Notice.

When a Call Redemption Event in relation to a Series of Tokenized Securities and the Issuer gives an Issuer Call Redemption Notice, the Cash Euro Equivalent might be lower than the Issue Price at that time and the investor may therefore suffer a loss or does not receive the expected yield on his investment.

Furthermore, there is also the risk that the investors can only reinvest the amount received from the redemption at a lower yield.

## **b) Legal and regulatory risks**

### ***Compliance.***

Pursuant to the regulatory framework, which is currently applicable to the Issuer, it faces relatively low compliance requirements, as it is, for example, not directly responsible for "know your client" ("KYC") checks or anti-money laundering ("AML") checks of end investors. In this respect the Issuer relies on its Authorised Participants which have implemented the relevant KYC systems and procedures. Any breach of the compliance processes of the Authorised Participants or service providers could have a material adverse effect on the Issuer's core business, including reputational damage and significant legal and financial impact.

### ***Risks related to regulation of blockchain technologies and digital assets.***

The Tokenized Securities are issued in the form of security tokens. With the exception of the German Electronic Securities Act (*Gesetz zur Einführung elektronischer Wertpapiere – eWpG*), there is currently very little regulatory guidance regarding the issuance and settlement of securities on a blockchain. Various legislative and executive bodies in Germany, on a European level and in other countries may in the future, adopt laws, regulations, guidance, or other actions, which may severely impact the future development of securities issued in tokenized form. Failure by the Issuer or certain investors to comply with any laws, rules and regulations, some of which may not exist yet or are subject to interpretation and may be subject to change, could result in a variety of adverse consequences, including civil penalties and fines and may negatively affect the rights of investors under a Series of Tokenized Securities.

### ***Dependence on certain service providers and potential conflicts of interest.***

The Issuer is dependent on a number of service providers to maintain the issue of a Series of Tokenized Securities and the security relating to such Series of Tokenized Securities. These include Tradias GmbH ("Tradias"), who is operating the platform as well as Authorised Participants, the Paying Agent, the Security Trustee and the Crypto Custodian. Should there be a material adverse change in cooperation with any existing service provider and a suitable alternative be unavailable or impracticable, the Issuer shall have the right to redeem the Tokenized Securities.

## **c) Internal control and IT risks**

### ***Attacks by "hackers" and sabotage from outside the Issuer.***

The whole business of the Issuer depends on certain information technology (IT) infrastructure. Additionally, service providers (e.g., Tradias) also rely on IT systems to provide services to the Issuer. Both the Issuer's IT systems and IT systems of such service providers may be hacked by criminals. The Issuer is exposed to the risk of being partially, temporarily or even permanently prevented from carrying out its business activities or it may become in breach of its covenants and even become insolvent, and any Tokenholders may lose a part or all of their investment in a Series of Tokenized Securities due to such security breach.

## **2.2 RISKS RELATING TO THE TOKENIZED SECURITIES**

An investment in a Series of Tokenized Securities involves certain risks associated with the characteristics, specification and type of the Tokenized Securities which could lead to substantial losses that Tokenholders would have to bear in the case of selling their Tokenized Securities. Risks regarding a Series of Tokenized Securities comprise, *inter alia*, the following risks:

a) **Risks related to the nature and the Terms and Conditions of the Tokenized Securities**

*Risks in connection with a potential termination by the investors*

Pursuant to the Terms and Conditions, each Tokenholder has the option to request redemption of its Tokenized Securities at any time. Tokenized Securities will at the option of the investor either be redeemed in cash or by delivery of units of the Underlying.

There is a risk that the Issuer may not be able to redeem the Tokenized Securities, at all or in a timely manner. The Issuer's ability to redeem Tokenized Securities will be limited by its access to funds or units of the Underlying, respectively, at the time of redemption. At the time of redemption, the Issuer may be required to redeem the Tokenized Securities and any other amounts owed by it under other outstanding indebtedness immediately. The funds or units of the Underlying for such redemption would be derived from the Hedging Account or other available cash or other assets, including derivatives. However, there can be no assurance that sufficient funds or units of the Underlying will be available to make such repayments and any required redemption of the Tokenized Securities.

Furthermore, if a Tokenholder exercises its termination right due to a specific value of the Underlying and there is a delay in the redemption process, there is a risk that the value of the Underlying can fluctuate/decrease in that time period and that the investor as a result may receive a lower than expected yield.

*The Issuer is allowed at any time to perform a mandatory redemption in case certain events as specified in the Terms and Conditions materialise.*

The Issuer may at any time, in its sole and absolute discretion, elect to terminate and redeem all but not some of the Tokenized Securities in case of occurrence of certain events as further specified in the Terms and Conditions (each an "**Issuer Call Redemption Event**"). In exercising such discretion, the Issuer is not required to have any regard to the interests of the investors, and investors may receive less, or substantially less, than their initial investment. There is a risk that the Issuer exercises the Issuer Call at a time that when the Cash Euro Equivalent is lower than the Issue Price and the investor therefore suffers a loss or does not receive the expected yield on his investment.

Furthermore, there is also the risk that the investors can only reinvest the amount received from the redemption at a lower yield.

*No recourse and no guarantee.*

Pursuant to the Terms and Conditions, the Tokenized Securities will be obligations solely of the Issuer. In particular, the Tokenized Securities will not be obligations of, or guaranteed by any partner or affiliate of the Issuer or any direct or indirect holder of the Issuer.

No person has guaranteed the performance of the Issuer's obligations, and no investor has any direct rights of enforcement against any such person. As a result, investors bear the risk of a loss of part or all of their investment.

*The Tokenized Securities are subject to transaction costs and charges.*

When Tokenized Securities are purchased or sold, several types of incidental costs (including transaction fees and commissions) are incurred in addition to the purchase or sale price of the Tokenized Securities. These incidental costs may significantly reduce or eliminate any profit from holding the Tokenized Securities. To the extent that additional – domestic or foreign – parties are involved in the execution of an order, including, but not limited to, domestic dealers or brokers in foreign markets, investors may also be charged for the brokerage fees, commissions and other fees and expenses of such parties (third party costs). In addition to such costs directly related to the purchase of securities (direct costs), potential investors must also take into account any follow-up costs (such as custody fees).

The specific risk is that such additional costs may lower the yield of the investment substantially. Therefore, potential investors should inform themselves about any additional costs incurred in

connection with the purchase, custody or sale of the Tokenized Securities before investing in the Tokenized Securities.

***There is no limitation on the amount of debt which the Issuer may incur in the future***

There is no restriction on the amount of indebtedness that the Issuer may incur in the future. Any raising of additional debt capital by the Issuer which is not subordinated to the Tokenized Securities will increase the Issuer's debt ratio unless its own funds are also increased to a corresponding extent. An increased level of indebtedness simultaneously increases the risk of a default by the Issuer under the Tokenized Securities due to the fact that the Issuer is exposed to increased payment obligations as a result of raising additional debt. In addition, the raising of additional debt capital may reduce the amount that the investors will receive on their claims in the event of liquidation or insolvency of the Issuer. In such case, the market price of the Tokenized Securities may be negatively affected, and the investors might not be able to realize the expected yield from the investment in the Tokenized Securities.

**b) Risks related to the Underlying**

***A decline in the value of the Underlying will affect the value of the Tokenized Securities.***

The value of the Tokenized Securities is affected by the price of the Underlying. The performance of the investment management company has a direct impact on the value of the Tokenized Securities. The amount received by Tokenholders upon redemption of the Tokenized Securities is either a cash amount in euro at which the investment management company is willing to purchase the number of units of the Underlying or the respective number of units itself (the "**Cash Euro Equivalent**"). In case the value of the Underlying declines the Cash Euro Equivalent declines as well and an investor might suffer a loss.

***Investing in the Tokenized Securities does not correspond to a direct investment in the Underlying.***

Investors should be aware that the market value of the Tokenized Securities does not exclusively depend on the prevailing price of the Underlying and changes in the prevailing price of the Underlying may not necessarily result in a comparable change in the market value of the Tokenized Securities. The performance of the Tokenized Securities may differ significantly from direct holdings of the Underlying as a result of negative effects of fees and charges, in addition to the negative effect of any other risks described herein. The return on the Tokenized Securities may not reflect the return if the investor had actually owned the Underlying and held such investment for a similar period.

***The Hedging Position might suffer a shortfall in case the Authorized Participant does not meet its delivery obligations.***

While the Issuer intends to create a Hedging Position that reflects 100 per cent. of the value of each outstanding Series of Tokenized Securities, this might not at all times be the case. A shortfall in the Hedging Position might occur if the Authorized Participant defaults before it has met its obligation to deliver units of the Underlying or pay the Cash Euro Equivalent to the Issuer. In order to guarantee the investors' exchange or repayment option in this scenario as well, the Issuer hedges the possibility of acquiring units of the Underlying via derivatives. The residual risk is that the redemption requests exceed the Hedging Position with the Authorized Participant becoming insolvent after the redemption requests were made and could not initiate the transfer of the unit of the Underlying or payment of the Cash Euro Equivalent to the Issuer. This may impair or preclude the Issuer's ability to make any redemptions under the Tokenized Securities.

**c) Other related risks**

***Liquidity Risk***

The Tokenized Securities are not admitted to trading on any stock exchange or other trading venue. They can only be sold over-the-counter (OTC) by the investors. There is a risk that an active and liquid secondary market for the Tokenized Securities may not develop or, if it does develop, that it will not continue. The liquidity of the Tokenized Securities could also be subject to fluctuations and could deteriorate, in particular, as a result of repurchases and redemptions. Since the Tokenized Securities are not admitted to trading on any stock exchange or other trading venue, their saleability is severely limited

or may not be possible at all. In an illiquid market, an investor might not be able to sell its Tokenized Securities at any time at fair market prices. In the worst case, the investor will not be able to sell its Tokenized Securities at all. In addition, there will be no price determined on the stock exchange.

### ***Currency Risk***

Potential investors should bear in mind that an investment in the Tokenized Securities involves currency risks. This presents certain risks relating to currency conversions if financial activities of an investor are denominated principally in a currency or currency unit other than the euro. If, after the purchase of the Tokenized Securities by the relevant investor, the Euro loses value against the home currency of the purchaser, the investor will receive, if so chosen by the investor and assuming the solvency of the Issuer, at redemption of the Tokenized Securities the same amount in Euro that it provided to the Issuer at the time. However, converted into the investor's home currency, this Euro amount may correspond to a lower equivalent value than the investor had to spend for the purchase of the Tokenized Securities. Changes in currency exchange rates result from various factors, such as macro-economic factors, speculative transactions and interventions by central banks and governments. In addition, government and monetary authorities may impose (as some have done in the past) exchange controls that could adversely affect an applicable currency exchange rate. As a result, investors may receive less redemption amounts than expected.

### ***Internet disruptions***

The functionality of the register in which the Tokenized Securities are registered, which is operated by the Issuer and from which all transfers as well as a list of those blockchain addresses to which the tokens representing the Tokenized Securities are assigned can be obtained (the "**Register**") and of the digital wallet of the investors depends on the functionality of the internet or the internet connection. A significant disruption of the internet or the internet connection could significantly impair the functionality and operation of the Register and the digital wallet or prevent it entirely until the internet disruption is resolved. Such disruption could adversely affect an investment in the Tokenized Securities and the Issuer's ability to operate. During this time, an investor would not be able to access its digital wallet and thus the Tokenized Securities.

### ***Risks associated with blockchain technology***

The Tokenized Securities are issued on the basis of the blockchain technology, which is a relatively young and unproven technology. There is a risk that this technology is subject to technical difficulties or that its functionality is impaired by external influences. A partial or complete breakdown of the blockchain used jeopardizes the repayment of the Tokenized Securities.

### ***Risk of losses of Tokenized Securities due to fraud, accident or similar***

Investors should be aware of the risk of losing their Tokenized Securities provided that they hold or deposit the Tokenized Securities in a digital wallet. The Tokenized Securities are stored in a digital wallet on a computer, laptop or smartphone. Digital wallets have a public key and a private key or password that allows their owners to access them. However, digital wallets are not impervious to hacking. Therefore, similar to traditional wallets, the Tokenized Securities or money from digital wallets could be stolen. In addition, the loss of the key or password to a digital wallet (including unauthorized copies of the key or password or any portion thereof) could result in the Tokenized Securities or money stored in the digital wallet being lost forever. There are no central offices that record passwords or issue replacement passwords.

### ***Hacks of digital wallets or the Register***

There are various types of hacks of digital wallets or of the Register. Such a hack could adversely affect an investment in the Tokenized Securities. In this context, a "hack" refers to any unauthorized access to the private keys necessary to sign transactions on the blockchain transferring value out of the relevant digital wallet. This includes "brute force" attacks (i.e. attacks seeking to obtain the information regarding the private keys through a trial-and-error method, whereby software is used to generate a large number of consecutive guesses). While such attacks are currently unlikely, it should be noted that the development of quantum computing is expected to make such attacks possible. A hack of the



investor's digital wallet or the Register could result in the loss of the Tokenized Securities. Although significant measures are taken to prevent a hack of the Register, it is not possible to completely eliminate this risk.

***Security granted to secure the Tokenized Securities may be unenforceable or enforcement of the Security may be delayed.***

Pursuant to the Terms and Conditions the Issuer has granted to the Security Trustee a lien on the Hedging Account for the benefit of the investors as collateralisation of the claims of the investors under the Tokenized Securities. These security arrangements may not be sufficient to protect the investors in the event of the Issuer's bankruptcy or liquidation due to various reasons. There is a legal risk that the security interest is not enforceable and there could be uncertainties on how to enforce such Security or changes in legislation. In addition, the enforcement of the Security may be delayed.

***Fraud risk arising from third parties.***

The Issuer is interacting with a number of third parties, including, but not limited to, Tradias as platform operator, the Security Trustee, the Paying Agent, the Crypto Custodian etc. The Issuer is also relying on its own staff for its operations. As a result, the Issuer is exposed to the risk of misconduct, negligence or fraud by these third parties and its employees. This could result in serious reputational or financial harm or damage to the assets of the Issuer which are pledged as a security for the Tokenized Securities and also result in losses for the investors in the Tokenized Securities. It is not always possible to deter misconduct and the internal control systems set up by the Issuer or the relevant third parties may not always be effective. Also, these risks may not be fully covered by insurance.

***Realisation of Security and role of the Security Trustee.***

The Security Trustee may take any action permitted by the Terms and Conditions and the relevant security documents in an enforcement scenario without having regard to the effect of such action on individual investors. Fees, costs and expenses for the Security Trustee will need to be paid in advance. All fees, costs and expenses related to the enforcement will be the sole responsibility of, and will be deducted from any payments made to, the relevant investors.

### 3. IMPORTANT NOTICE

The Base Prospectus should be read and construed with any supplement hereto and with any other documents incorporated by reference and, in relation to any issue of a Series of Tokenized Securities, with the relevant Final Terms.

Tokenized Securities issued under this Base Prospectus have not been, and will not be, registered under the U.S. Securities Act of 1933, as amended (the "**Securities Act**"). The Tokenized Securities are being offered outside the United States of America (the "**United States**" or "**U.S.**") in accordance with Regulation S under the Securities Act ("**Regulation S**"), and may not be offered, sold or delivered within the United States except pursuant to an exemption from, or in a transaction not subject to, the registration requirements of the Securities Act.

**This Base Prospectus may not be used for the purposes of an offer or solicitation by anyone in any jurisdiction in which such offer or solicitation is not authorised or to any person to whom it is unlawful to make such offer or solicitation.**

**The validity of this Base Prospectus will expire at the end of 30 April 2025. There is no obligation to supplement a base prospectus in the event of significant new factors, material mistakes or material inaccuracies if a base prospectus is no longer valid.**

#### ***MIFID II PRODUCT GOVERNANCE / TARGET MARKET***

The Final Terms in respect of any Series of Tokenized Securities will include a legend entitled "MiFID II Product Governance" which will outline the target market assessment in respect of each Series of Tokenized Securities and which channels for distribution of the Tokenized Securities are appropriate. Any person subsequently offering, selling or recommending the Tokenized Securities (a "**distributor**") should take into consideration the target market assessment; however, a distributor subject to MiFID II is responsible for undertaking its own target market assessment in respect of each Series of Tokenized Securities (by either adopting or refining the target market assessment) and determining appropriate distribution channels.

A determination will be made in relation to each issue about whether, for the purpose of the MiFID Product Governance rules under EU Delegated Directive 2017/593 (the "**MiFID Product Governance Rules**"), any dealer subscribing for any Tokenized Securities is a manufacturer in respect of such Tokenized Securities, but otherwise neither any dealer(s) nor any of their respective affiliates will be a manufacturer for the purpose of the MiFID Product Governance Rules.

Any websites included in this Base Prospectus are for information purposes only, do not form part of this Base Prospectus and have not been scrutinised or approved by BaFin as competent authority.

#### **4. RESPONSIBILITY STATEMENT**

Tradias Issuance GmbH with its registered office at Rossmarkt 21, 60311 Frankfurt am Main, Germany accepts responsibility for the information contained in this Base Prospectus and declares to the best of its knowledge that the information contained in this Base Prospectus is in accordance with the facts and that the Base Prospectus makes no omission likely to affect its import.

## 5. CONSENT TO THE USE OF THE BASE PROSPECTUS

Each financial intermediary subsequently reselling or finally placing a Series of Tokenized Securities - if and to the extent this is so expressed in the Final Terms relating to a particular Series of Tokenized Securities - is entitled to use this Base Prospectus in Austria, Belgium, Bulgaria, Croatia, Cyprus, the Czech Republic, Denmark, Estonia, Finland, France, Greece, Hungary, Iceland, Ireland, Italy, Latvia, Liechtenstein, Lithuania, Luxembourg, Malta, The Netherlands, Norway, Poland, Portugal, Romania, Slovakia, Slovenia, Spain and Sweden for the subsequent resale or final placement of the Tokenized Securities comprised in such Series of Tokenized Securities during the relevant offer period (as set out in the relevant Final Terms) during which a subsequent resale or final placement of the Tokenized Securities can be made, provided however, that this Base Prospectus is still valid in accordance with the Prospectus Regulation. The Issuer accepts responsibility for the information given in this Base Prospectus also with respect to such subsequent resale or final placement of the Tokenized Securities.

**The Issuer may give consent to additional financial intermediaries after the date of the relevant Final Terms to the use of this Base Prospectus as described above and, if they do so, the Issuer or the financial intermediaries will publish the above information in relation to them on their website.**

The Issuer's consent to use this Base Prospectus for the subsequent resale or final placement of Tokenized Securities by the financial intermediaries may be restricted to certain jurisdictions and subject to the condition that each financial intermediary complies with all applicable laws and regulations in force in the respective jurisdictions as well as such conditions that are stated in the relevant Final Terms.

This Base Prospectus and the relevant Final Terms may only be delivered to potential investors together with all supplements published before such delivery. Any supplement to this Base Prospectus will be available for viewing in electronic form on the website of the Issuer ([www.tradius.de](http://www.tradius.de)) and on the website of the European Securities and Markets Authority (<https://www.esma.europa.eu>).

**In the event of an offer being made by a financial intermediary, such financial intermediary shall provide information to investors on the Terms and Conditions of a Series of Tokenized Securities at the time of that offer.**

**Any financial intermediary using this Base Prospectus shall state on its website that it uses this Base Prospectus and the relevant Final Terms in accordance with this consent and the conditions attached to this consent.**

## **6. LISTING AND TRADING**

The Tokenized Securities issued under this Programme will not be admitted to trading on any stock exchange at all. The Tokens may be admitted to trading on a DLT MTF subject to Regulation (EU) 2022/858 of the European Parliament and of the Council of 30 May 2022 on a pilot regime for market infrastructures based on distributed ledger technology, and amending Regulations (EU) No 600/2014 and (EU) No 909/2014 and Directive 2014/65/EU.

## **7. REASONS FOR THE OFFER AND USE OF PROCEEDS**

Unless specified otherwise in the relevant Final Terms, the reason for the issue of Tokenized Securities under the Programme is primarily to finance the general business development of the Issuer. The Issuer will create the Hedging Position, primarily consisting of units of the Underlying, as well as cash or other assets, including derivatives. The Issuer intends to create a Hedging Position reflecting 100 per cent. of the value of each outstanding Series of Tokenized Securities. The estimated total expenses of the issue and/or offer of each Series of Tokenized Securities will be specified in the relevant Final Terms of each issue of Tokenized Securities.

## **8. NOTIFICATION**

The Issuer has requested BaFin to provide the competent authorities in Austria, Belgium, Bulgaria, Croatia, Cyprus, the Czech Republic, Denmark, Estonia, Finland, France, Greece, Hungary, Iceland, Ireland, Italy, Latvia, Liechtenstein, Lithuania, Luxembourg, Malta, The Netherlands, Norway, Poland, Portugal, Romania, Slovakia, Slovenia, Spain and Sweden with a certificate of approval attesting that this Base Prospectus has been drawn up in accordance with the Prospectus Regulation.

## **9. AUTHORISATION**

The establishment of the Programme and the issuance of any Series of Tokenized Securities under this Base Prospectus have been authorised by a resolution of Tradias Issuance GmbH, dated 6 March 2024.



## 10. GENERAL INFORMATION ABOUT THE ISSUER

### 10.1 GENERAL INFORMATION

The Issuer's legal name is Tradius Issuance GmbH.

The Issuer is a limited liability company (*Gesellschaft mit beschränkter Haftung*) organised and existing under the laws of Germany, with its registered office in Roßmarkt 21, 60311 Frankfurt am Main, Germany and registered with the commercial register of the local court (*Amtsgericht*) of Frankfurt am Main, Germany, under the registration number HRB 125428.

The Issuer was founded on 13 October 2021. As a special purpose vehicle which has been established primarily for the issuance of the Tokenized Securities, the Issuer does not conduct any operational business except for the activity as described below ("*10.3 Principal Activities and Expected Financing of the Issuer*").

The Issuer has no employees except for the managing director.

The Issuer's Legal Entity Identifier (LEI) is 5299009CMRBW5U9HEJ15.

The website of the Issuer is [www.tradius.de](http://www.tradius.de) and the phone number is +49 69 25 72 00 – 0. The information on the website does not form part of this Base Prospectus and has not been scrutinised or approved by BaFin.

The Issuer does not carry out crypto-custody-business within the meaning of section 1 (1a) sentence 2 no 6 of the German Banking Act ("**KWG**") or section 2 (3) no 1 of the German Investment Firm Act ("**WpIG**") and does therefore not require a license pursuant to section 32 KWG or section 15 WpIG. The Issuer does not safekeep, administrate and/or protect cryptographic assets or private cryptographic keys for others.

### 10.2 CORPORATE PURPOSE

Pursuant to Section 2 of the Issuer's articles of association, the objective of the Issuer is the administration of its own assets. The Issuer holds assets for its own purposes, values them and manages them. Furthermore, the purpose of the Issuer is also to provide IT services and other services relating to crypto-assets and financial instruments, including the issue of tokenized debt securities.

### 10.3 PRINCIPAL ACTIVITIES AND EXPECTED FINANCING OF THE ISSUER

The only activity of the Issuer is the issue of tokenized securities. The Issuer expects to finance its activities by the issue of such securities.

## 10.4 ORGANISATIONAL STRUCTURE

The Issuer is a wholly-owned subsidiary of Tradias GmbH ("**Tradias**"). The Issuer does not have any subsidiaries of its own. It is a special purpose vehicle that has been established primarily for the issuance of tokenized securities.

The following chart provides an overview of the structure of the group of which the Issuer forms part as of the date of this Base Prospectus:

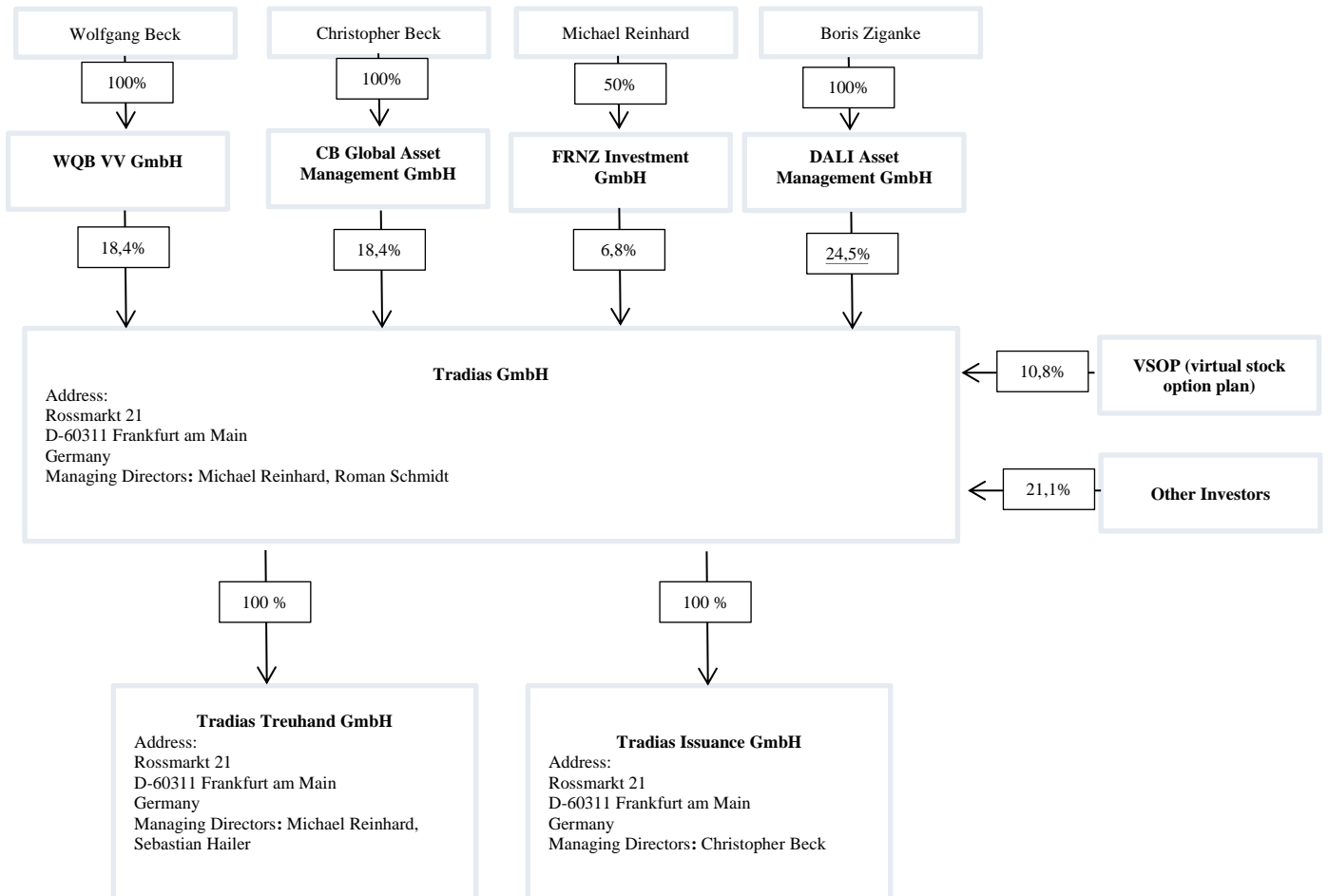

As mentioned above, the Issuer's sole shareholder is Tradias (see also "10.9. Major Shareholders"), with its registered office at Roßmarkt 21, 60311 Frankfurt am Main, Germany.

The table below sets out the shareholders of Tradias:

Shareholder	Shareholding percentage
Wolfgang Rudolf Beck (through WQB Vermoegensverwaltungs GmbH)	18.4 per cent (20.6. per cent of voting rights)
Christopher Ferdinand Beck (through CB Global Asset Management GmbH)	18.4 per cent (20.6. per cent of voting rights)
Michael Reinhard (through FRNZ Investment GmbH)	6.8 per cent (7.6 per cent of voting rights)
Boris Ziganke (through DALI Asset Management GmbH)	24.5 per cent (27.5 per cent of voting rights)
Holders of virtual shares under virtual stock option plan (VSOP)	10.8 per cent (no voting rights)
Other investors, jointly represented	21.1 per cent (23.7 per cent of voting rights)

## 10.5 MANAGEMENT BOARD

Currently, the Issuer's management board consists of one managing director. The current managing director of the Issuer is:

Name	Occupation
Christopher Ferdinand Beck	Managing Director

The managing director can be contacted at Roßmarkt 21, 60311 Frankfurt am Main, Germany.

The managing director has declared that no potential conflicts of interest between any duties to the Issuer and his private interest or other duties exist.

## 10.6 SHARE CAPITAL

The registered share capital (*Stammkapital*) of the Issuer amounts to EUR 25,000. The share capital has been fully paid up. All shares carry the same rights and obligations. The shares were created under German law.

## 10.7 FISCAL YEAR

The fiscal year of the Issuer is the calendar year.

The Issuer's statutory auditor for the Annual Financial Statements (as defined below) is D & P Wirtschaftsprüfung GmbH, with their registered office at Biebergasse 2, 60313 Frankfurt am Main. D & P Wirtschaftsprüfung GmbH is a member of the German chamber of public accountants (*Wirtschaftsprüferkammer*).

## 10.8 RATING

The Issuer has not been rated.

## 10.9 MAJOR SHAREHOLDERS

The Issuer's sole shareholder is Tradias. The shareholders of Tradias are set out in the table above (*10.4 Organisational Structure*).

## **10.10 INTERESTS OF NATURAL AND LEGAL PERSONS INVOLVED IN THE ISSUE/OFFER**

Various companies affiliated with the Issuer are involved in the conception and implementation of the issuance of the Tokenized Securities, including Tradias GmbH as parent company of the Issuer and Tradias Treuhandgesellschaft mbH, a sister company of the Issuer, acting as Security Trustee. In addition, one shareholder of Tradias GmbH (i.e., Wolfgang Beck) is the sole shareholder and Chief Executive Officer of Bankhaus Scheich Wertpapierspezialist AG and one shareholder of Tradias GmbH (Boris Ziganke) is the Chief Operating Officer of Bankhaus Scheich Wertpapierspezialist AG, acting as Authorised Participant. Tradias GmbH and Bankhaus Scheich Wertpapierspezialist AG may offer their services in relation to the issuance and placement of the Tokenized Securities on terms that do not qualify as arms' length conditions. Each of these parties has an interest in the successful placement of the Tokenized Securities.

If not specified otherwise in the Final Terms for a Series of Tokenized Securities, other than the interests described above, there are no interests, in particular, no conflicts of interest that are material to the issue and offer of the Tokenized Securities.

## **10.11 MATERIAL CONTRACTS AND TRANSACTIONS**

The Issuer has entered into the following agreements and has conducted the following transactions which are material to the Issuer's ability to meet its obligations to Tokenholders:

- Security Trust Agreement entered into between the Issuer and Tradias Treuhandgesellschaft mbH in its function as the Security Trustee dated on or around the date of the relevant Final Terms in relation to each Series of Tokenized Securities. The Security Trust Agreement provides for provisions on the Security in favour of the Security Trustee for the benefit of the investors and the Security Trustee itself relating to all of the Issuer's rights, title, interest and benefit, present and future, in, to and from the Hedging Account maintained by a custodian bank on behalf of the Issuer in which the relevant Hedging Position is booked and the bank account in which the cash forming part of the Hedging Position is held. The Security Trust Agreement is governed by the laws of Germany.
- Authorised Participant Agreement entered into between the Issuer and Bankhaus Scheich Wertpapierspezialist AG. The Authorised Participant Agreement relates to the initial purchase of the Tokenized Securities and re-sale of the same. Furthermore, the Authorised Participant Agreement provides for a fee for Bankhaus Scheich Wertpapierspezialist AG where the same procures units of the Underlying for the Hedging Position (to the extent that the Authorised Participant does not purchase the Tokenized Securities with units of the Underlying).
- Custodian Agreement entered into between the Issuer and V-Bank, Munich, acting as custodian bank in relation to the maintenance of the Hedging Account and the cash account for each Series of Tokenized Securities.
- Management Agreement entered into between the Issuer and Tradias GmbH relating to the general management and administration of the Issuer, including accounting, legal services and certain IT support services to the Issuer in relation to all Series of Tokenized Securities
- Arranger Agreement entered into between the Issuer and Tradias GmbH. The Arranger Agreement includes in particular the indemnification of the Issuer from current costs related to the implementation of the project relating to the issuance of the Tokenized Securities.

## **10.12 TREND INFORMATION**

There are no known trends, uncertainties, demands, commitments or events that are reasonably likely to have a material effect on the Issuer's prospects for at least the current financial year.

## **10.13 MATERIAL ADVERSE CHANGE IN THE PROSPECTS**

There has been no material adverse change in the prospects of the Issuer since 31 December 2023, the date of its last published audited financial information.

#### **10.14 SIGNIFICANT CHANGE IN THE FINANCIAL PERFORMANCE**

There has been no significant change in the financial performance of the Issuer since 31 December 2023, i.e., the end of the last financial period for which financial information has been published to the date of this Base Prospectus.

#### **10.15 SIGNIFICANT CHANGE IN THE FINANCIAL POSITION**

There has been no significant change in the financial position of the Issuer since 31 December 2023, i.e., the end of the last financial period for which financial information has been published to the date of this Base Prospectus.

#### **10.16 BORROWING AND FUNDING**

There have been no material changes in the borrowing and funding structure of the Issuer since 31 December 2023.

#### **10.17 LEGAL AND ARBITRATION PROCEEDINGS**

During the previous 12 months, there have been no governmental, legal or arbitration proceedings, (including any such proceedings which are pending or threatened, of which the Issuer is aware), which may have, or have had in the recent past, a significant effect on the financial position or profitability of the Issuer.

## 11. HISTORICAL FINANCIAL INFORMATION

The Issuer was incorporated on 13 October 2021. The Issuer's financial information set forth in this Base Prospectus has been derived from the Issuer's annual financial statements as of 31 December 2022 and 31 December 2023 (the "**Financial Statements**").

The Financial Statements have been prepared in accordance with the German Commercial Code (*Handelsgesetzbuch*).

The Annual Financial Statements have been audited and an unqualified auditor's report has been issued.

The fiscal year of the Issuer commences on 1 January and ends on 31 December. The next financial statements of the Issuer will be prepared as of and for the year ended 31 December 2024.

## **12. GENERAL DESCRIPTION OF THE TOKENIZED SECURITIES AND THE PROGRAMME**

### **12.1 DESCRIPTION OF THE TOKENIZED SECURITIES**

#### **a) Form of Tokenized Securities, Status**

Tokenized Securities issued under this Base Prospectus are issued under German law and shall be qualified as debt securities *sui generis* (*Schuldverschreibungen eigener Art*). The Tokenized Securities are issued in tokenized form and do not have a fixed maturity date. The obligations under the Tokenized Securities constitute direct, unsubordinated and secured obligations of the Issuer ranking *pari passu* among themselves.

The Tokenized Securities are based on the polygon-sidechain of the ethereum-blockchain or any other blockchain the Issuer might select for the tokenization of the Tokenized Securities. The Tokenized Securities will be registered in a register operated by the Issuer from which all transfers as well as a list of those blockchain addresses to which the tokens representing the Tokenized Securities are assigned can be obtained (the "**Register**"). The Issuer operates the Register with a software solution provided by an external service provider. The operation of the Register includes the ability to view entries made in the Register and the capacity to pull the relevant data from the Register, such as the blockchain addresses to which the tokens representing the Tokenized Securities are assigned. Such data will also be included in a digital file off the blockchain. Each blockchain address can then be assigned to the respective user in order to give notices or for purposes of redemption.

If tokens are held in a collective wallet, only the blockchain address of this collective wallet and the crypto custodian as operator of such wallet will be visible in the Register as a Tokenholder. Furthermore, all transfers of tokens can be viewed in the Register, provided that these are not token transfers within the same collective wallet. Token transfers within the same collective wallet, i.e. where the same collective wallet is both the seller's and the purchaser's wallet, do not take place via the blockchain and are therefore not disclosed in the Register. Such transfers are recorded in the crypto custodian's transaction register, as operator of such collective wallet. The Issuer and Tradias have access to the transaction register administered by the crypto custodian.

#### **b) Transfer of Tokenized Securities**

The Tokenized Securities will be transferred via assignment (*Abtretung*) pursuant to section 398 of the German Civil Code. Such transfer will be effected through entry of the blockchain address of the new Tokenholder in the Register or if such Tokenholder's Tokenized Securities are held in a collective wallet through entry in the crypto custodian's transaction register. Tokenized Securities can only be transferred via the Blockchain and through entry in the Register or through entry in the crypto custodian's transaction register.

#### **c) Custody by Tokenholders**

The Tokenized Securities are held in wallets by investors and only investors will have access to their wallets.

#### **d) Issue Price of the Tokenized Securities and Yield**

The issue price of the Tokenized Securities will be stated in the relevant Final Terms.

The yield of the Tokenized Securities cannot be calculated at the issue date of the Tokenized Securities.

#### **e) Interest on the Tokenized Securities and Redemption of the Tokenized Securities**

Depending on the Underlying, the Tokenized Securities may or may not provide for interest payments, which is set out in the Final Terms. The Tokenized Securities do not have a fixed maturity date.

The Tokenized Securities will only be redeemed upon occurrence of an Issuer's Call or a Tokenholder's Exercise.

(a) Mandatory Redemption upon Issuer's Call

Tokenized Securities may be redeemed by the Issuer upon the occurrence of an Issuer Redemption Event (as further described in the Terms and Conditions) at their Redemption Amount.

(b) Redemption upon Tokenholder's Exercise

Each Tokenholder may request redemption of its Tokenized Securities at any time at their Redemption Amount.

Tokenized Securities will either be redeemed in cash or by delivery of units of the Underlying at the option of the Tokenholder.

Where the Tokenholder elects redemption in cash, the Issuer shall pay to the Tokenholder on the relevant Redemption Date the product of (i) the Cash Euro Equivalent in euro, calculated as at the relevant Calculation Date, and (ii) the number of Tokenized Securities to be redeemed, less a Structuring Fee, if any (the "**Cash Redemption**").

"**Cash Euro Equivalent**" means the cash amount in euro at which the relevant Investment Management Company of the Underlying (each as defined below) is willing to purchase one Unit of the Underlying on a Calculation Date and which the investment management company has published or otherwise announced accordingly, commercially rounded to two decimal places and, to the extent that the investment management company does not itself report such cash amount in euro, the euro equivalent of such cash amount on the basis of the conversion rate applicable on the respective Redemption Date.

Where the Tokenholder elects delivery of units of the Underlying, the Issuer shall deliver of Units of the Underlying in a number equal in aggregate value to the amount of the Cash Redemption, less a Delivery Charge, if any, and with settlement of any fractional amounts in euro.

(c) Effects of the value of the Underlying

The value and performance of the Tokenized Securities materially depends on the value and performance of the respective Underlying.

In accordance with their derivative structure based on the Issuer's payment and delivery obligations to Tokenholders under the Tokenized Securities, the Tokenized Securities are expected (subject to the deduction of any fees and costs) to track the performance of the Underlying nearly 1:1.

f) **Description of the Underlying**

The Underlying means the units of an open-ended investment fund issued by an investment management company, having its registered seat in Germany, Ireland, Luxembourg or France and regulated by Directive 2014/91/EU of 23 July 2014 and relevant delegated regulations (the "**Investment Management Company**"), as further specified in the Final Terms (the "**Underlying**").

The investment guidelines of the open-ended investment funds will provide for the fund assets to consist of the assets referred to in sections 193 to 198 of the German Capital Investment Code (*Kapitalanlagegesetzbuch – KAGB*) or equivalent in the jurisdictions mentioned above.

The Issuer may also, from time to time, issue Tokenized Securities with Underlyings other than those listed above.

The Tokenized Securities shall track the value of the Underlying. The issue price will be equal to the amount in euro at which the Investment Management Company is prepared to sell a unit of the Underlying on the relevant issue date, while the redemption will be through delivery of the Underlying or cash redemption, in each case calculated or equivalent to an amount in euro at which the Investment Management Company is willing to purchase one unit of the Underlying on the relevant calculation date pertaining to the relevant redemption date.



**g) Sale of Tokenized Securities in the Secondary Market**

A Tokenholder may sell its Tokenized Securities via an OTC market at any time (provided that a liquid market exists). The Issuer will not charge any fees. However, broker fees may be incurred.

Bankhaus Scheich Wertpapierspezialist AG ("**BHS**"), or any other suitable third person specified in the applicable Final Terms, will undertake to take over the market making for the trading of the Tokenized Securities (the "**Market Maker**"). The Market Maker will not enter into any direct client relationships in the secondary market with private clients within the meaning of section 67 (3) German Securities Trading Act (*Wertpapierhandelsgesetz – WpHG*) or with natural persons. In order to facilitate the trading of the Tokenized Securities, the Market Maker will enter into cooperation agreements with Authorised Participants, financial intermediaries and other commission agents and will provide them with bid and offer prices to facilitate the trading of the Tokenized Securities on an ongoing basis. Trading of the Tokens will technically be facilitated through an online platform which is operated by Tradias (the "**Platform**").

**h) ECB Eligibility**

The Tokenized Securities are not intended to be held in a manner which would allow for them to be recognised as eligible collateral for Eurosystem monetary policy and intra-day credit operations by the Eurosystem either upon issue or at any or all times during their life.

**i) Ratings**

The Tokenized Securities have not been rated.

**j) Clearing and Settlement**

Payments and transfers of any Series of Tokenized Securities will not be settled through any clearing system.

**k) Determination of issue specific variables**

Certain variables, such as values, dates and other information, are determined individually, on an issue specific case by case basis, in relation to each Series of Tokenized Securities. Such variables will be determined in the respective Final Terms relating to each Series of Tokenized Securities.

The information so determined are:

- Underlying;
- Issue Date;
- Issue Price;
- Series No. and Tranche No.;
- International Securities Identification Number (ISIN);
- Indication where information about the past and the future performance of the Underlying and its/their volatility can be obtained;
- Indication whether or not the issuer intends to provide post issuance information;
- Countries where the offer to the public takes place;
- Information with regard to the manner, place and date of the publication of the results of the offer;
- Names and addresses of the entities which have a firm commitment to act as intermediaries in secondary trading, providing liquidity through bid and offer rates and description of the main terms of their commitment (*Market Makers*);

- Names and addresses of the Crypto Custodian.

## 12.2 DESCRIPTION OF THE SECURITY

The Issuer will grant the following security (the "**Security**") for the benefit of the Tokenholders and Tradias Treuhandgesellschaft mbH (the "**Security Trustee**"):

### a) **Security over Hedging Account**

Pursuant to section 13 of the Terms and Conditions the Issuer shall grant to the Security Trustee a lien on the Hedging Account (the "**Security**") for the benefit of the Tokenholders as collateralisation of the claims of the Tokenholders under the Tokenized Securities, whereby "**Hedging Account**" means the custody account of the Issuer with a custodian bank in which the relevant Hedging Position is booked and the bank account in which the cash forming part of the Hedging Position is held. "**Hedging Position**" means the amount which the Issuer invests (taken from the Issue Price) to secure the performance of its obligations under the Tokenized Securities. The Hedging Position may consist of units in the Underlying, cash or other assets as further specified in the Security Trust Agreement. Each time the Issuer issues a Tokenized Security, it will acquire a unit of the Underlying and add it to the Hedging Position. The obligation to deliver the units of the Underlying lies with the Authorised Participant who is the primary purchaser or subscriber of each Tokenized Security. As a result, the Hedging Position will contain as many units of the Underlying as Tokenized Securities were issued, which corresponds to a hedging ratio of 100% once the unit of the Underlying has been delivered to the Issuer. This typically occurs within the usual settlement period for the units of the Underlying, corresponding to a settlement period of two business days (T+2).

However, since the Issuer can issue Tokenized Securities outside the usual settlement period of the units of the Underlying, and due to the fact that the Tokenized Securities can be settled earlier than the units of the Underlying can be delivered into the Hedging Account, there can be a temporary shortfall in the Hedging Position. For example, the Tokenized Security may be issued on a Friday, but the delivery of the unit of the Underlying will not take place until the following Tuesday. However, as soon as the Authorised Participant can meet its delivery obligation in accordance with the settlement cycles of the Underlying, the investors' claims are again 100% covered.

The temporary shortfall will not be noticeable for the investors to the extent that their claim to exchange the Tokenized Securities 1:1 for units of the Underlying is also linked to the settlement period of the Underlying, i.e., a redemption request cannot be satisfied sooner than within two business days (T+2).

In order to mitigate any potential shortfall in the Hedging Portfolio due to the Authorised Participant not meeting its obligations to deliver units of the Underlying to the Hedging Account, the Issuer could acquire units of the Underlying directly or via derivatives.

### b) **Security Trust Agreement**

In relation to each Series of Tokenized Securities, the Issuer and the Security Trustee have entered or will enter into a Security Trust Agreement, pursuant to which the Security Trustee will be appointed to act as security trustee of and for the benefit of the Tokenholders and the Security Trustee itself in connection with the administration and the handling of the rights of the Tokenholders against the Issuer as well as among themselves in relation to the Security. In particular, the Security Trustee shall (i) administer and enforce such Security which has been created by way of pledge (*Verpfändung*) or otherwise transferred to it under an accessory security right (*akzessorische Sicherheit*); and (ii) act in relation to the Security in accordance with the terms and subject to the conditions of the Security Trust Agreement.

### c) **Enforcement of Security**

The Security Trust Agreement grants to the Security Trustee the right to enforce the Security in full or in part upon notification by a Tokenholder that the Issuer has not complied with its obligations to provide either cash or Tokenized Securities to the relevant Tokenholder following a request pursuant to section 9.3 of the Terms and Conditions. The Security Trustee shall only be entitled to enforce the Security, if the requirements set forth in sections 1273, 1204 et seq. of the German Civil Code are

satisfied (*Pfandreife*). The Security Trustee is entitled to grant the Issuer a remedy period of up to 30 days in which time no actions enforcement of the Security may be undertaken, in order to provide the Issuer with sufficient time to remedy, arrange for the breach to be waived by the party affected or otherwise cure the cause of the Security becoming enforceable.

### 13. TERMS AND CONDITIONS

#### TERMS AND CONDITIONS OF THE TOKENIZED SECURITIES (the "Terms and Conditions")

#### *EMISSIONSBEDINGUNGEN DER TOKENBASIERTEN SCHULDVERSCHREIBUNGEN (die "Emissionsbedingungen")*

These Terms and Conditions are written in the English and German language. The German language version shall be the only legally binding version. The English version, shall be provided for convenience only.

*Diese Emissionsbedingungen sind in englischer und deutscher Sprache abgefasst. Die deutsche Sprachfassung ist rechtlich bindend. Die englische Sprachfassung wird nur als unverbindliche Übersetzung zur Verfügung gestellt.*

#### **Token-Bedingungen der tokenbasierten Schuldverschreibungen**

[•]

**der**

**Tradius Issuance GmbH, Frankfurt am Main  
Legal Entity Identifier (LEI):  
5299009CMRBW5U9HEJ15**

(die „Token-Bedingungen“)

#### **Token Terms and Conditions of the Tokenized Securities**

[•]

**of**

**Tradius Issuance GmbH, Frankfurt am Main  
Legal Entity Identifier (LEI):  
5299009CMRBW5U9HEJ15**

(the “Token Conditions”)

#### **1. Definitionen**

Für die Zwecke dieser Token-Bedingungen gelten die folgenden Begriffsbestimmungen:

„**Ausgabepreis**“ bezeichnet [•].

„**Bankarbeitstag**“ ist ein Tag, an dem das Trans-European Automated Real-Time Gross Settlement Express Transfer (TARGET2) System Zahlungen abwickelt und Geschäftsbanken in Frankfurt am Main im Allgemeinen geöffnet sind, um Zahlungen abzuwickeln.

„**Barrückzahlung**“ ist eine Zahlung des Emittenten am jeweiligen Rückzahlungstag im Betrag des Produktes aus Geld-Euro-Gegenwert in Euro, berechnet zum jeweiligen Berechnungstag, und Anzahl der zurückzugebenden tokenbasierten Schuldverschreibungen, ggf. abzüglich einer Strukturierungsgebühr.

„**Begebungstag**“ bezeichnet [•].

„**Berechnungstag**“ bezeichnet denjenigen Tag, (i) zu dem eine Gläubiger-Rückzahlungsmittelteilung dem Emittenten gemäß Ziffer 9.3 zugegangen ist oder (ii) zu dem eine Emittentenkündigungserklärung durch

#### **1. Definitions**

For the purposes of these Token Conditions, the following definitions apply:

“**Issue Price**” means [•].

“**Banking Day**” means a day on which the Trans-European Automated Real-Time Gross Settlement Express Transfer (TARGET2) system settles payments and commercial banks in Frankfurt am Main are generally open to process payments.

“**Cash Redemption**” means a payment by the Issuer on the relevant Redemption Date in the amount of the product of the Cash Euro Equivalent in euro, calculated as at the relevant Calculation Date, and the number of Tokenized Securities to be redeemed, less a Structuring Fee, if any.

“**Issue Date**” means [•].

“**Calculation Date**” means the date (i) on which a Holder Put Redemption Notice is received by the Issuer pursuant to Condition 9.3 or (ii) on which an Issuer Call Redemption Notice is given by the Issuer

den Emittenten gemäß Ziffer 9.2 abgegeben wird, oder, wenn dieser Tag kein Bankarbeitstag ist, den diesem Tag vorausgegangenen letzten Bankarbeitstag.

„**Blockchain**“ bezeichnet [●].

„**Brief-Euro-Gegenwert**“ bezeichnet den Geldbetrag in Euro, zu dem die Kapitalverwaltungsgesellschaft am jeweiligen Begebungstag oder, wenn der Begebungstag kein Bankarbeitstag ist, an dem diesem vorausgegangenen, letzten Bankarbeitstag, zum Verkauf einer Einheit des Underlyings bereit ist und den die Kapitalverwaltungsgesellschaft entsprechend veröffentlicht bzw. anderweitig bekannt gemacht hat, kaufmännisch gerundet auf zwei Nachkommastellen und, soweit die Kapitalverwaltungsgesellschaft diesen Geldbetrag selbst nicht in Euro ausweist, der Euro-Gegenwert dieses Geldbetrages auf Grundlage des am jeweiligen Begebungstag geltenden Umrechnungskurses.

„**Einheit des Underlyings**“ bezeichnet [●].

„**Emittent**“ bezeichnet die Tradias Issuance GmbH, eine nach deutschem Recht errichtete Gesellschaft mit beschränkter Haftung mit Sitz in Frankfurt am Main, eingetragen im Handelsregister des Amtsgerichts Frankfurt am Main unter HRB 125428.

„**Emittentenkündigung**“ hat die Bedeutung wie in Ziffer 9.2 definiert.

„**Emittentenkündigungserklärung**“ hat die Bedeutung wie in Ziffer 9.2 definiert.

„**Emittentenkündigungsereignis**“ hat die Bedeutung wie in Ziffer 9.2 definiert.

„**Emittentenkündigung-Rückzahlungstag**“ hat die Bedeutung wie in Ziffer 9.2 definiert.

„**Erster Begebungstag**“ bezeichnet [●].

„**Ertragsbeteiligung**“ hat die Bedeutung wie in Ziffer 8.2 definiert.

„**Fälligkeitstag**“ bezeichnet einen Tag, an dem eine Zahlung fällig wird.

„**Geld-Euro-Gegenwert**“ bezeichnet den Geldbetrag in Euro, zu dem die Kapitalverwaltungsgesellschaft an einem Berechnungstag zum Kauf einer Einheit des Underlyings bereit ist und den die Kapitalverwaltungsgesellschaft entsprechend veröffentlicht bzw. anderweitig bekannt gemacht hat, kaufmännisch gerundet auf zwei Nachkommastellen und, soweit die Kapitalverwaltungsgesellschaft diesen Geldbetrag selbst nicht in Euro ausweist, der Euro-Gegenwert dieses Geldbetrages auf Grundlage

pursuant to Condition 9.2 or, if such date is not a Banking Day, the last Banking Day preceding such date.

“**Blockchain**” means [●].

“**Ask Price Euro Equivalent Value**” means the monetary amount in euro at which the Investment Management Company is prepared to sell a Unit of the Underlying on the relevant Issue Date or, if the Issue Date is not a Banking Day, on the last Banking Day preceding such Issue Date and which the Investment Management Company has published or otherwise announced accordingly, commercially rounded to two decimal places and, to the extent that the Investment Management Company does not itself report this cash amount in euros, the euro equivalent of this cash amount on the basis of the conversion rate applicable on the respective Issue Date.

“**Unit of the Underlying**” means [●].

“**Issuer**” means Tradias Issuance GmbH, a limited liability company incorporated under German law with its registered office in Frankfurt am Main, registered in the commercial register of the local court of Frankfurt am Main under HRB 125428.

“**Issuer Call**” has the meaning as defined in Condition 9.2.

“**Issuer Call Redemption Notice**” has the meaning as defined in Condition 9.2.

“**Issuer Call Redemption Event**” has the meaning as defined in Condition 9.2.

“**Issuer Call Redemption Date**” has the meaning as defined in Condition 9.2.

“**First Issue Date**” means [●].

“**Profit Participation**” has the meaning as defined in Condition 8.2.

“**Maturity Date**” means a date on which a payment is due.

“**Cash Euro Equivalent**” means the cash amount in euro at which the Investment Management Company is willing to purchase one Unit of the Underlying on a Calculation Date and which the Investment Management Company has published or otherwise announced accordingly, commercially rounded to two decimal places and, to the extent that the Investment Management Company does not itself report such cash amount in euro, the euro equivalent of such cash amount on the basis of the conversion rate applicable

des am jeweiligen Rückzahlungstag geltenden Umrechnungskurses. Für den Fall, dass die Kapitalverwaltungsgesellschaft an einem Berechnungstag den Geld-Euro-Gegenwert nicht gemäß den vorstehenden Bestimmungen dieser Definition veröffentlicht bzw. anderweitig bekannt macht, wird der zuletzt veröffentlichte Geld-Euro-Gegenwert herangezogen.

„**Gläubiger**“ bezeichnet die Inhaber der tokenbasierten Schuldverschreibungen.

„**Gläubiger-Rückzahlungsmitteilung**“ hat die Bedeutung wie in Ziffer 9.3 definiert.

„**Gläubiger-Rückzahlungstag**“ bezeichnet den Kalendertag, der zehn (10) Bankarbeitstage nach dem Tag liegt, zu dem eine Gläubiger-Rückzahlungsmitteilung dem Emittenten gemäß Ziffer 9.3 zugegangen ist.

„**Hedging-Depot**“ bezeichnet [●].

„**Kapitalverwaltungsgesellschaft**“ bezeichnet [●].

„**Kryptoverwahrer**“ ist [●].

„**Lieferung**“ bezeichnet die Lieferung von Einheiten des Underlyings in einer Anzahl, die im Gesamtwert dem Betrag der Barrückzahlung, ggf. abzüglich einer Lieferungsgebühr und unter Abgeltung etwaiger Spitzenbeträge in Euro, entspricht, wobei der Wert einer Einheit des Underlyings dem Geld-Euro-Gegenwert zum betreffenden Berechnungstag entspricht.

„**Lieferungsgebühr**“ bezeichnet [●].

„**Plattform**“ bezeichnet die technisch betriebene Online-Plattform für den Ersterwerb und den Handel der Token.

„**Register**“ bezeichnet das Register welches vom Emittenten geführt wird, aus dem sich sämtliche Übertragungen sowie die Liste der Blockchainadressen ergeben, denen die Token, die die tokenbasierten Schuldverschreibung repräsentieren, zugeordnet sind.

„**Rückzahlung**“ bezeichnet die Leistung, die ein Gläubiger gemäß Ziffer 9.1 gegen Rückgabe einer tokenbasierten Schuldverschreibung beanspruchen kann und die nach Wahl des Gläubigers – sofern in diesen Token-Bedingungen nicht abweichend geregelt – entweder in einer Barrückzahlung oder einer Lieferung besteht.

„**Rückzahlungstag**“ hat die Bedeutung wie in Ziffer 9.1 definiert.

on the respective Redemption Date. In the event that the Investment Management Company does not publish or otherwise announce the Cash Euro Equivalent on a Calculation Date in accordance with the foregoing provisions of this definition, the most recently published Cash Euro Equivalent shall be used.

“**Holder**” means the Holders of the Tokenized Securities.

“**Holder Put Redemption Notice**” has the meaning as defined in Condition 9.3.

“**Holder Put Redemption Date**” means the calendar day which is ten (10) Banking Days after the day on which a Holder Put Redemption Notice is received by the Issuer pursuant to Condition 9.3.

“**Hedging Account**” means [●].

“**Investment Management Company**” means [●].

“**Crypto Custodian**” means [●].

“**Delivery**” means the delivery of Units of the Underlying in a number equal in aggregate value to the amount of the Cash Redemption, less a Delivery Charge, if any, and with settlement of any fractional amounts in euro, the value of one Unit of the Underlying being the Cash Euro Equivalent as at the relevant Calculation Date.

“**Delivery Charge**” means [●].

“**Platform**” means the technically operated online platform for the initial purchase and trading of the Token.

“**Register**” means the register operated by the Issuer from which all transfers as well as a list of those blockchain addresses to which the tokens representing the Tokenized Securities are assigned can be obtained.

“**Redemption**” means the performance which a Holder may claim pursuant to Condition 9.1 against surrender of a Tokenized Security and which, at the option of the Holder, unless otherwise provided in these Token Conditions, consists of either a Cash Redemption or Delivery.

“**Redemption Date**” has the meaning as defined in Condition 9.1.

„**Sammel-Wallet**“ bezeichnet eine von einem Kryptoverwahrer verwaltete und für die Verwahrung von Token zugelassene Wallet, die der gemeinsamen Verwahrung der Token mehrerer Token-Inhaber dient.

„**Sicherheit**“ bezeichnet das zugunsten der Token-Inhaber dem Sicherheitentreuhänder eingeräumte Pfandrecht am Hedging-Depot.

„**Sicherheitentreuhänder**“ bezeichnet die Tradias Treuhandgesellschaft mbH, eine nach deutschem Recht errichtete Gesellschaft mit beschränkter Haftung mit Sitz in Frankfurt am Main, eingetragen im Handelsregister des Amtsgerichts Frankfurt am Main unter HRB 125300.

„**Sicherheiten-Treuhandvertrag**“ hat die Bedeutung wie in Ziffer 13.1 definiert.

„**Strukturierungsgebühr**“ bezeichnet [●].

„**Token**“ bezeichnet die digital auf der Blockchain dezentral gespeicherte Abbildung der tokenbasierten Schuldverschreibungen des Emittenten mit der Bezeichnung [●].

„**Token-Inhaber**“ bezeichnet diejenige Person, die entweder (i) über die ihr von einem Kryptoverwahrer zugeordnete Nutzer-ID und das Transaktionsregister dieses Kryptoverwahrers im Hinblick auf in eine Sammel-Wallet bei diesem Kryptoverwahrer verwahrte Token oder (ii) über die entsprechende Blockchain-Adresse im Register identifiziert werden kann.

„**tokenbasierte Schuldverschreibungen**“ bezeichnet mehrere, „**tokenbasierte Schuldverschreibung**“ eine Blockchain-basierte Schuldverschreibung als Wertpapier *sui generis*, die vom Emittenten unter diesen Token-Bedingungen ausgegeben werden und jeweils eine Einheit des Underlyings nach Maßgabe dieser Token-Bedingungen wirtschaftlich abbilden.

„**Transaktionsregister**“ bezeichnet das vom Kryptoverwahrer geführte Verzeichnis von Token-Inhabern, denen die in einem Sammel-Wallet bei diesem Kryptoverwahrer verwahrten Token zugeordnet sind.

„**Underlying**“ bezeichnet [●].

„**Wallet**“ bezeichnet eine jede für die Verwahrung von Token geeignete und zugelassene Verwahrlösung.

„**Whitelisting**“ hat die Bedeutung wie in Ziffer 4.1 definiert.

„**Collective Wallet**“ means a Wallet managed by a Crypto Custodian and approved for the custody of tokens, which is used for the collective custody of the Tokens of multiple Tokenholders.

„**Security**“ means the lien on the Hedging Account granted in favour of the Tokenholders to the Security Trustee.

„**Security Trustee**“ means Tradias Treuhandgesellschaft mbH, a limited liability company incorporated under the laws of Germany with its registered office in Frankfurt am Main, registered in the commercial register of the local court of Frankfurt am Main under HRB 125300.

„**Security Trust Agreement**“ has the meaning as defined in Condition 13.1.

„**Structuring Fee**“ means [●].

„**Token**“ means the digital representation of the Issuer's Tokenized Securities designated [●], stored on the Blockchain in a decentralised way.

„**Tokenholder**“ means the person who can be identified either (i) by the user ID assigned to it by a Crypto Custodian and the Transaction Register of that Crypto Custodian in respect of Tokens held in a Collective Wallet with that Crypto Custodian or (ii) by the relevant Blockchain address in the Register.

„**Tokenized Securities**“ means multiple notes, „**Tokenized Security**“ means one blockchain-based note as security *sui generis* issued by the Issuer under these Token Conditions and each economically representing one Unit of the Underlying in accordance with these Token Conditions.

„**Transaction Register**“ means the register of Tokenholders who are assigned the Tokens held in a Collective Wallet by the Crypto Custodian which is operated by the Crypto Custodian.

„**Underlying**“ means [●].

„**Wallet**“ means any custodial solution suitable and approved for the safekeeping of Tokens.

„**Whitelisting**“ has the meaning as defined in Condition 4.1.

„Zahlstelle“ bezeichnet die Bankhaus Scheich Wertpapierspezialist AG, eine nach deutschem Recht errichtete Aktiengesellschaft mit Sitz in Frankfurt am Main, eingetragen im Handelsregister des Amtsgerichts Frankfurt am Main unter HRB 103196 oder eine nach Ziffer 11.2 an deren Stelle tretende andere Zahlstelle.

„Zahlungstag“ bezeichnet einen Fälligkeitstag oder, wenn ein Fälligkeitstag kein Bankarbeitstag ist, den auf den Fälligkeitstag unmittelbar folgenden, nächsten Bankarbeitstag, an dem eine Zahlung tatsächlich zu leisten ist; wegen einer solchen Verschiebung einer Zahlung von einem Fälligkeitstag auf einen abweichenden Zahlungstag entsteht kein Anspruch auf Zahlung von Verzugszinsen.

## 2. Allgemeine Bestimmungen

- 2.1 Der Emittent begibt beginnend mit dem Ersten Begebungstag und nachfolgend an jedem weiteren Begebungstag nach Maßgabe dieser Token-Bedingungen bis zu [●] Stück tokenbasierte Schuldverschreibungen zum jeweiligen Ausgabepreis.
- 2.2 Der Emittent ist berechtigt, das auf die tokenbasierten Schuldverschreibungen eingezahlte Kapital im Rahmen seines satzungsmäßigen Unternehmensgegenstandes frei zu verwenden.
- 2.3 Die tokenbasierten Schuldverschreibungen gewähren den Gläubigern ausschließlich die in diesen Token-Bedingungen niedergelegten schuldrechtlichen Ansprüche und Rechte und keine darüber hinausgehenden Ansprüche oder Rechte, insbesondere keine Mitgliedschaftsrechte, wie z.B. Teilnahme-, Mitwirkungs- und/oder Stimmrechte. Mit dem Erwerb der tokenbasierten Schuldverschreibungen ist weder vom Emittenten noch von dem Gläubiger der Abschluss einer stillen Beteiligung im Sinne der §§ 230 ff. HGB beabsichtigt. Die tokenbasierten Schuldverschreibungen sind nicht an einem Liquidationserlös beteiligt.
- 2.4 Jede tokenbasierte Schuldverschreibung räumt dem jeweiligen Gläubiger das Recht ein, vom Emittenten eine Rückzahlung nach Maßgabe von Ziffer 9.3 zu verlangen.
- 2.5 Der Emittent generiert eine der Anzahl der jeweils auszugebenden tokenbasierten Schuldverschreibungen entsprechende Anzahl an Token. Wenn und soweit die Blockchain

“Paying Agent” means Bankhaus Scheich Wertpapierspezialist AG, a stock corporation incorporated under German law with its registered office in Frankfurt am Main, registered in the commercial register of the local court of Frankfurt am Main under HRB 103196 or any other paying agent replacing it in accordance with Condition 11.2.

“Payment Date” means a Maturity Date or, if a Maturity Date is not a Banking Day, the next Banking Day immediately following the Maturity Date on which a payment is actually to be made; no right to payment of default interest shall arise by reason of any such postponement of a payment from a Maturity Date to a different payment date.

## 2. General provisions

- 2.1 The Issuer shall issue, commencing on the First Issue Date and on each subsequent Is-sue Date thereafter, in accordance with these Token Conditions, up to [●] Units of Tokenized Securities at the respective Issue Price.
- 2.2 The Issuer is entitled to freely use the capital paid up on the Tokenized Securities within the scope of its statutory corporate purpose.
- 2.3 The Tokenized Securities shall grant the Holders solely the claims and rights under the law of obligations set out in these Token Conditions and no further claims or rights, in particular no membership rights, such as participation, involvement and/or voting rights. With the acquisition of the Tokenized Securities, neither the Issuer nor the Holder intends to enter into a silent partnership within the meaning of §§ 230 et seq. of the German Commercial Code (*Handelsgesetzbuch - HGB*). The Tokenized Securities are not entitled to participate in any liquidation proceeds.
- 2.4 Each Tokenized Security grants the respective Tokenholder the right to demand repayment from the Issuer in accordance with Condition 9.3.
- 2.5 The Issuer shall generate a number of Tokens equal to the number of Tokenized Securities to be issued from time to time. If and to the extent that the Blockchain has become unusable or the



unbenutzbar wird oder die Blockchain ganz oder teilweise die für die Übertragung der Token notwendigen Leistungen einstellt oder nicht mehr unterstützt, ist der Emittent berechtigt, die tokenbasierten Schuldverschreibungen ohne Zustimmung der Gläubiger auf einer anderen Blockchain digital abbilden zu lassen. Eine Änderung der Blockchain wird gemäß Ziffer 9.2 bekannt gemacht.

- 2.6 Jeder Token verkörpert jeweils eine tokenbasierte Schuldverschreibung. Die Token dienen als Legitimation der Stellung als materiell Berechtigter und damit Gläubiger der tokenbasierten Schuldverschreibungen. Das bedeutet, dass, vorbehaltlich Ziffer 5.2 nur die Token-Inhaber berechtigt sind, die in diesen Token-Bedingungen geregelten Rechte der Gläubiger hinsichtlich der entsprechenden tokenbasierten Schuldverschreibungen geltend zu machen bzw. auszuüben. Vorbehaltlich Ziffer 5.2 ist der Emittent daher ausschließlich berechtigt und verpflichtet, seine Verpflichtungen aus den tokenbasierten Schuldverschreibungen gegenüber solchen Personen zu erbringen, die als Token-Inhaber identifiziert sind, sodass die Leistung gegenüber einer solchen Person auch dann schuldbeitfreiende Wirkung für den Emittenten hat, wenn diese nicht der materiell berechtigte Gläubiger sein sollte.
- 2.7 Der Emittent wird zur Generierung der Token einen sog. Smart Contract durch die Tradius GmbH erstellen lassen. Die Tradius GmbH verwaltet im Rahmen dieser für den Emittenten erbrachten Dienstleistung auch den private key des Smart Contracts. Dem Smart Contract der Token ist auf der Blockchain das Register zugeordnet. Das Register beinhaltet eine Liste mit denjenigen Adressen auf der Blockchain, denen Token zugeordnet sind. Soweit Token in einer Sammel-Wallet verwahrt werden, ist im Register nur die Blockchain-Adresse dieser Sammel-Wallet ersichtlich. Dem Register können ferner alle Übertragungen von Token entnommen werden, sofern es sich dabei nicht um Token-Übertragungen innerhalb derselben Sammel-Wallet handelt. Token-Übertragungen innerhalb derselben Sammel-Wallet, bei denen also dieselbe Sammel-Wallet sowohl Veräußerer- als auch Erwerber-Wallet ist, erfolgen nicht über die Blockchain und können daher auch nicht über das Register eingesehen werden. Solche Übertragungen werden im Transaktionsregister des Kryptoverwahrers eingetragen. Der Emittent und die Tradius
- 2.6 Each Token embodies one Tokenized Security. The Tokens serve as legitimation of the position as material beneficiary and thus Tokenholder of the Tokenized Security. This means that, subject to Condition 5.2, only the Tokenholders are entitled to assert or exercise the rights of the Holders governed by these Token Conditions in respect of the relevant Tokenized Securities. Subject to Condition 5.2, the Issuer is therefore exclusively entitled and obliged to perform its obligations under the Tokenized Securities vis-à-vis such persons who are identified as Tokenholders, so that the performance vis-à-vis such person constitutes full discharge of the Issuer's obligations even if such person is not the materially entitled Holder.
- 2.7 To generate the Tokens, the Issuer will have created a so-called “**Smart Contract**” by Tradius GmbH as operator of the platform. As part of this service provided to the Issuer, Tradius GmbH also manages the private key of the Smart Contract. The Register is assigned to the Smart Contract of the Tokens on the Blockchain. The Register contains a list of those addresses on the Blockchain to which Tokens are assigned. If Tokens are held in a Collective Wallet, only the Blockchain address of such Collective Wallet is visible in the Register. Furthermore, all transfers of Tokens can be obtained from the Register, provided that these are not Token transfers within the same Collective Wallet. Token transfers within the same Collective Wallet, i.e. where the same Collective Wallet is both the seller and acquirer wallet, do not take place via the Blockchain and can therefore not be viewed via the register. Such transfers are recorded in the Crypto Custodian's Transaction Register. The Issuer and Tradius GmbH as operator of the platform shall obtain access to the Transaction Register from the Crypto Custodian. The Transaction

GmbH als Betreiber der Plattform erhalten von dem Kryptoverwahrer Einsicht in das Transaktionsregister. Für andere Dritte ist das Transaktionsregister des Kryptoverwahrers nicht einsehbar.

Register of the Crypto Custodian cannot be accessed by other third parties.

### 3. Status

- 3.1 Die tokenbasierten Schuldverschreibungen begründen unmittelbare, nicht nachrangige und besicherte Verbindlichkeiten des Emittenten gegenüber dem jeweiligen Gläubiger, die untereinander gleichrangig sind und mindestens im gleichen Rang mit allen anderen gegenwärtigen und zukünftigen Verbindlichkeiten des Emittenten stehen, ausgenommen solche Verbindlichkeiten, denen auf Grund zwingender gesetzlicher Vorschriften Vorrang zukommt.
- 3.2 Die tokenbasierten Schuldverschreibungen werden nicht verbrieft. Es werden weder eine Globalurkunde noch Einzelurkunden oder Zinsscheine über die tokenbasierten Schuldverschreibungen ausgegeben.

### 3. Status

- 3.1 The Tokenized Securities constitute direct, unsubordinated and secured obligations of the Issuer to the relevant Holder ranking *pari passu* among themselves and at least *pari passu* with all other present and future obligations of the Issuer, except for such obligations which are accorded priority under mandatory provisions of statutory law.
- 3.2 The Tokenized Securities will not be represented by a global note and no definitive notes or interest coupons will be issued in respect of the Tokenized Securities.

### 4. Übertragung

- 4.1 Die Übertragung der tokenbasierten Schuldverschreibungen ist nur möglich auf Dritte, die
- a) sich und ihre jeweilige Wallet auf der Plattform angemeldet, die erforderliche Geldwäscheprüfung absolviert und die für die Ausübung der Rechte unter der jeweiligen tokenbasierten Schuldverschreibung erforderlichen Angaben (insbesondere die für die Vornahme von Zahlungen erforderlichen Angaben) übermittelt haben, oder
- b) durch Einbindung eines zugelassenen Wertpapier- oder Kreditinstituts, das zugleich Verpflichteter gemäß § 2 GwG ist, eine Geldwäscheprüfung absolviert und in diesem Rahmen die für die Ausübung der Rechte unter der jeweiligen tokenbasierten Schuldverschreibung erforderlichen Angaben (insbesondere die für die Vornahme von Zahlungen erforderlichen Angaben) angegeben haben.

### 4. Transfer

- 4.1 The transfer of the Tokenized Securities is only possible to third parties who
- a) have registered themselves and their respective Wallet on the Platform, completed the required money laundering check and submitted the information required to exercise the rights under the respective Tokenized Security (in particular, the information required to make payments); or
- b) have completed a money laundering check through the involvement of an authorised securities or credit institution which is also an party obliged pursuant to § 2 German Money Laundering Act (*Geldwäschegesetz* - GwG) and in this context have provided the information required to exercise the rights under the respective Tokenized Security (in particular, the information required to make payments).

(insgesamt das „**Whitelisting**“). Das Whitelisting wird von der Tradius GmbH als Betreiberin der Plattform und Verwalterin des Smart Contract

(collectively, the “**Whitelisting**”). The Whitelisting shall be carried out by Tradius GmbH as operator of the Platform and administrator of the Smart Contract.

durchgeführt. Nur auf Wallets Dritter, für die das Whitelisting erfolgt ist, können Token übertragen werden.

Tokens can only be transferred to third party wallets for which whitelisting has taken place.

- 4.2 Die Übertragung der tokenbasierten Schuldverschreibungen erfolgt, vorbehaltlich Ziffer 4.1, im Wege einer Vereinbarung zwischen dem Gläubiger und dem Erwerber, durch die der Erwerber in die Stellung des Gläubigers eintritt. Alle Erklärungen, die für die Übertragung der Stellung als Gläubiger und die Vertragsübernahme erforderlich sind, gelten durch Übertragung des maßgeblichen Tokens als vom Gläubiger und dem Erwerber vorbehaltlos abgegeben und angenommen. Eine Übertragung einzelner Ansprüche oder Rechte aus den tokenbasierten Schuldverschreibungen ist nicht zulässig. Der Emittent erteilt bereits hiermit seine Einwilligung in Übertragungen der Token und damit zugleich der tokenbasierten Schuldverschreibungen nach Maßgabe dieser Token-Bedingungen, sodass es hierfür keiner weiteren Zustimmung des Emittenten bedarf.
- 4.2 Subject to Condition 4.1, the transfer of the Tokenized Securities shall be effected by way of an agreement between the Holder and the acquirer by which the acquirer assumes the position of Holder. Any statements required for the transfer of the position as Holder and the transfer of the agreement shall be deemed to have been made and accepted unconditionally by the Holder and the acquirer by transfer of the relevant Token. A transfer of individual claims or rights under the Tokenized Securities is not permitted. The Issuer hereby already gives its consent to transfers of the Tokens and thus also of the Tokenized Securities in accordance with these Token Conditions, so in this respect, no further consent of the Issuer is required.
- 4.3 Die Wirksamkeit der Übertragung von tokenbasierten Schuldverschreibungen steht – in Abhängigkeit von der Art der Token-Übertragung (wie nachstehend beschrieben) – unter folgender aufschiebender Bedingung:
- 4.3 The effectiveness of the transfer of Tokenized Securities is subject to the following condition precedent, depending on the type of Token transfer (as described below):
- a) Soweit die Übertragung von Token innerhalb einer Sammel-Wallet stattfindet, d.h. bei der die Sammel-Wallet sowohl Veräußerer- als auch Erwerber-Wallet ist, unter der aufschiebenden Bedingung, dass eine Umschreibung der Inhaberschaft im Hinblick auf den betreffenden Token im Transaktionsregister zugunsten des Erwerbers erfolgt. Eine Umschreibung in diesem Sinne gilt als erfolgt, wenn die durch die jeweilige Übertragung von Token bedingte Veränderung des Token-Bestands des Veräußerers und des Token-Bestands des Erwerbers auf der Plattform durch Registereintragung vollzogen wurde.
- a) Insofar as the transfer of Tokens takes place within a Collective Wallet, i.e. where the Collective Wallet is both the seller's and the acquirer's Wallet, subject to the condition precedent that a transfer of ownership with regard to the relevant Token is made in the Transaction Register in favour of the acquirer. A transfer in this sense shall be deemed to have taken place if the change in the Token portfolio of the seller and the Token portfolio of the acquirer resulting from the respective transfer of Tokens has been effected by entry in the Register;
- b) In allen anderen Fällen der Übertragung von Token unter der aufschiebenden Bedingung, dass eine technische Übertragung des betreffenden Tokens von dem Veräußerer an den Erwerber auf der Blockchain erfolgt. Eine Übertragung in diesem Sinne gilt als erfolgt, wenn der Status einer solchen Transaktion im Register mit dem für die jeweils benutzte Blockchain kennzeichnenden Erfolgseintrag bestätigt wird.
- b) Any other case of transfer of Tokens is subject to the condition precedent that a technical transfer of the relevant Token from the seller to the acquirer takes place on the Blockchain. A transfer in this sense shall be deemed to have taken place when the status of such transaction is confirmed in the Register by the successful entry characterising the Blockchain used in each case.
- 4.4 Soweit nicht abweichend geregelt, können tokenbasierte Schuldverschreibungen im Wege
- 4.4 Unless specified otherwise, Tokenized Securities may be transferred by way of

der Einzelrechtsnachfolge nur gemeinsam mit dem entsprechenden Token übertragen werden.

- 4.5 Um gesetzlichen Verpflichtungen und behördlichen oder gerichtlichen Anordnungen nachzukommen, können Token auch ohne oder gegen den Willen der Token-Inhaber übertragen oder gelöscht werden.

## 5. Berechtigungsnachweis

- 5.1 Im Verhältnis zum Emittenten und zu jedem anderen Token-Inhaber gilt ein Token-Inhaber – vorbehaltlich Ziffer 5.2 – als Gläubiger im Hinblick auf die durch den jeweiligen Token digital abgebildeten tokenbasierten Schuldverschreibungen.
- 5.2 In Ausnahmefällen kann die materielle Berechtigung hinsichtlich der tokenbasierten Schuldverschreibungen und damit die Stellung als Gläubiger auch auf andere geeignete Weise gegenüber dem Emittenten nachgewiesen werden. Dies gilt insbesondere,
- a) wenn der Gläubiger keinen Zugriff mehr auf die Token hat oder
  - b) in allen Fällen, in denen die tokenbasierten Schuldverschreibungen als Teil einer Gesamtrechtsnachfolge übertragen werden.

In diesen Fällen ist ein geeigneter Nachweis für die materielle Berechtigung zu führen (im Erbfall z.B. durch Vorlage eines Erbscheins). Der Emittent kann die notwendigen technischen Maßnahmen ergreifen, damit der betroffene Gläubiger ein Token-Inhaber wird (z.B. können die betroffenen Token vom Emittenten durch Löschung für ungültig erklärt und neue Token an den betroffenen Gläubiger ausgegeben werden); Ziffer 4.1 gilt entsprechend.

## 6. Verwahrung

Jeder Token-Inhaber ist selbst für die Verwahrung seiner Token verantwortlich. Der Emittent ist nicht verpflichtet, den Token-Inhabern eine technische Lösung zur Verwahrung zu schaffen oder aufrechtzuerhalten. Für den Fall, dass Token-Inhaber Dritte mit der Verwahrung beauftragen oder eine von Dritten zur Verfügung gestellte technische Lösung zur Verwahrung der Token nutzen, richtet sich dies ausschließlich nach den maßgeblichen Bedingungen des jeweiligen Dritten.

singular succession only together with the corresponding token.

- 4.5 In order to comply with legal obligations and official or court orders, Tokens may also be transferred or deleted without or against the will of the Tokenholders.

## 5. Credentials

- 5.1 In relation to the Issuer and any other Tokenholder, a Tokenholder shall, subject to Condition 5.2, be deemed to be a holder in respect of the Tokenized Securities digitally represented by the relevant Token.
- 5.2 In exceptional cases, the material entitlement with regard to the Tokenized Securities and thus the status as holder may also be proven to the Issuer in another suitable manner. This applies in particular,
- a) if the holder no longer has access to the Tokens or
  - b) in any case where the Tokenized Securities are transferred as part of a universal succession.

In such cases, appropriate proof of material entitlement must be provided (in the case of inheritance, e.g. by presenting a certificate of inheritance). The Issuer may take the necessary technical measures for the affected holder to become a Tokenholder (e.g. the relevant Tokens may be invalidated by the Issuer by way of deletion and new Tokens may be issued to the affected holder); Condition 4.1 applies accordingly.

## 6. Custody

Each Tokenholder is responsible for the safekeeping of its Tokens. The Issuer is not obliged to provide or maintain a technical custody solution for the Tokenholders. In the event that Tokenholders entrust third parties with the safekeeping or use a technical solution provided by third parties for the safekeeping of the Tokens, this shall be governed exclusively by the relevant terms and conditions of the respective third party.

## **7. Änderung des Smart Contract**

7.1 Der den Token zugrunde liegende Smart Contract kann mit einem Mechanismus versehen sein, der es dem Emittenten ermöglicht, den entsprechenden Quellcode zu ändern. Von diesem Mechanismus darf jedoch ausschließlich Gebrauch gemacht werden, um

- a) Sicherheitsprobleme des zugrunde liegenden Smart Contracts zu beheben,
- b) nicht beabsichtigte Abweichungen von den Regelungen dieser Token-Bedingungen zu korrigieren,
- c) die Struktur des Quellcodes, Klassenschnittstellen, Control Flow zu ändern, soweit dies nicht den Token-Bedingungen widerspricht,
- d) den Quellcode in eine andere Programmiersprache zu übersetzen, soweit dies nicht den Token-Bedingungen widerspricht, oder
- e) Elemente des Smart Contracts zu ändern, die aufgrund externer Effekte unwirksam oder unpraktikabel geworden sind.

Sonstige Modifizierungen oder Änderungen des zugrunde liegenden Smart Contracts darf der Emittent nur mit Zustimmung aller Gläubiger vornehmen.

7.2 Sofern Änderungen des Smart Contracts gemäß Ziffer 7.1 erforderlich sind, ist der Emittent berechtigt, diese Token-Bedingungen entsprechend anzupassen. Entsprechende Änderungen werden den Gläubigern mit einer angemessenen Frist vor dem Wirksamwerden der Änderungen gemäß Ziffer 7.2 mitgeteilt. Widerspricht der Gläubiger der Geltung der geänderten Token-Bedingungen nicht innerhalb von vier (4) Wochen nach Zugang der Benachrichtigung über die Änderung dieser Token-Bedingungen, so gelten die geänderten Token-Bedingungen als vom Gläubiger akzeptiert. Der Emittent wird den Gläubigern in der Änderungsmitteilung auf die Bedeutung dieser Frist und die Rechtsfolgen des etwaigen Schweigens hinweisen.

## **8. Ertragsbeteiligung**

8.1 Es erfolgen keine laufenden Zinszahlungen auf die tokenbasierten Schuldverschreibungen.

## **7. Modification of the Smart Contract**

7.1 The Smart Contract underlying the Tokens may have a mechanism that allows the Issuer to modify the corresponding source code. However, this mechanism may only be used in order to

- a) address security issues of the underlying Smart Contracts,
- b) correct unintended deviations from the provisions of these Token Conditions,
- c) change the structure of the source code, class interfaces, control flow, as far as this does not contradict the Token Conditions,
- d) translate the source code into another programming language, provided this does not contradict the Token Conditions, or
- e) change elements of the Smart Contract that have become ineffective or impractical due to external effects.

Other modifications or changes to the underlying Smart Contract may be made by the Issuer only upon consent of all Holders.

7.2 If changes to the Smart Contract are required pursuant to Condition 7.1, the Issuer shall be entitled to amend these Token Conditions accordingly. The Holders shall be notified of any such amendments with a reasonable period of notice before the amendments take effect in accordance with Condition 7.2. If the holder does not object to the validity of the amended Token Conditions within four (4) weeks after receipt of the notification of the amendment of these Token Conditions, the amended Token Conditions shall be deemed accepted by the holder. In the amendment notification, the Issuer shall point out to the Holders the significance of this period and the legal consequences of any silence.

## **8. Profit Participation**

8.1 There will be no ongoing interest payments on the Tokenized Securities. There will also be no

Auf die tokenbasierten Schuldverschreibungen werden auch keine festen, periodenbezogenen Auszahlungen vorgenommen.

8.2 Sofern den Inhabern von Einheiten des Underlyings aus diesen ein Anspruch auf eine Leistung einer Ausschüttung zusteht, steht jedem Gläubiger im Hinblick auf jede von ihm gehaltene tokenbasierte Schuldverschreibung ein entsprechender Anspruch gegenüber dem Emittenten auf Ausschüttungsleistung zu, und zwar im Inhalt und Umfang so, wie wenn er selbst unmittelbar Inhaber einer Einheit des Underlyings wäre („**Ertragsbeteiligung**“).

8.3 Fälligkeitstag einer Ertragsbeteiligung ist jeweils der dritte auf den jeweiligen Valuta-Tag der zugrunde liegenden Ausschüttung auf Einheiten des Underlyings folgende Bankarbeitstag.

## 9. Laufzeit; Rückzahlung

9.1 Die tokenbasierten Schuldverschreibungen haben keine feste Laufzeit und keinen festgelegten Fälligkeitstag. Vorbehaltlich der weiteren Bestimmungen dieser Token-Bedingungen berechtigt jede tokenbasierte Schuldverschreibung den jeweiligen Gläubiger, nach seiner Wahl zu einer Rückzahlung vom Emittenten in Form von

- a) Barrückzahlung oder
- b) Lieferung.

Die Rückzahlung einer tokenbasierten Schuldverschreibung erfolgt zum Emittentenkündigung-Rückzahlungstag oder Gläubiger-Rückzahlungstag (jeder Emittentenkündigung-Rückzahlungstag oder Gläubiger-Rückzahlungstag, ein „**Rückzahlungstag**“) an den Gläubiger der jeweiligen tokenbasierten Schuldverschreibung.

9.2 Der Emittent ist berechtigt, die tokenbasierten Schuldverschreibungen bei Eintritt eines Emittentenkündigungsereignisses (wie nachstehend definiert) nach billigem Ermessen (ohne hierzu verpflichtet zu sein) durch Mitteilung gemäß Ziffer 9.2 („**Emittentenkündigungserklärung**“) zu kündigen („**Emittentenkündigung**“). Jedes der folgenden Ereignisse bezeichnet ein „**Emittentenkündigungsereignis**“:

- a) für einen fortwährenden Zeitraum von 90 (neunzig) Tagen ist der Gegenwart aller

fixed periodic payments on the Tokenized Securities.

8.2 To the extent that the holders of Units of the Underlying are entitled to a distribution from such Units, each holder shall have a corresponding claim against the Issuer for a distribution in respect of each Tokenized Security held by it, with the same content and scope as if it were itself the direct holder of a Unit of the Underlying (“**Profit Participation**”).

8.3 In each case, the Maturity Date of a Profit Participation is the third Banking Day following the relevant value date of the underlying distribution on Units of the Underlying.

## 9. Term; Repayment

9.1 The Tokenized Securities have no fixed maturity and no fixed Maturity Date. Subject as further provided in these Token Conditions, each Tokenized Security entitles the relevant Holder, at its option, to repayment from the Issuer in the form of

- a) Cash Redemption or
- b) Delivery.

The redemption of a Tokenized Security will be made on the Issuer Call Redemption Date or Holder Put Redemption Date (each Issuer Call Redemption Date or Holder Put Redemption Date, a “**Redemption Date**”) to the Holder of the relevant Tokenized Security.

9.2 The Issuer shall be entitled to call the Tokenized Securities upon the occurrence of an Issuer Call Redemption Event (as defined below) in its reasonable discretion (without being obliged to do so) by giving notice in accordance with Condition 9.2 (“**Issuer Call Redemption Notice**”) (“**Issuer Call**”). Each of the following events shall mean an “**Issuer Call Redemption Event**”:

- a) for a continuing period of 90 (ninety) days, on each such day the equivalent value of all outstanding Tokenized Securities is less than

ausstehenden tokenbasierten Schuldverschreibungen an jedem dieser Tage auf Grundlage des jeweiligen Geld-Euro-Gegenwerts geringer als EUR [●];

- |                                                                                                                                                                                                                                                                                                                                                                                                                                                                                                                                                                                                                                                                                                                                                                                                                                                                                                                                                                                                                                                                                                                                                                                                                                                                                                                                                                                                                                                                                                                                                                                                                                                                                                                                                                                                                                                                                                                                                                                                                                        |                                                                                                                                                                                                                                                                                                                                                                                                                                                                                                                                                                                                                                                                                                                                                                                                                                                                                                                                                                                                                                                                                                                                                                                                                                                                                                                                                                                                                                                                                                                                                                                                                                                                                                                                                                                                              |
|----------------------------------------------------------------------------------------------------------------------------------------------------------------------------------------------------------------------------------------------------------------------------------------------------------------------------------------------------------------------------------------------------------------------------------------------------------------------------------------------------------------------------------------------------------------------------------------------------------------------------------------------------------------------------------------------------------------------------------------------------------------------------------------------------------------------------------------------------------------------------------------------------------------------------------------------------------------------------------------------------------------------------------------------------------------------------------------------------------------------------------------------------------------------------------------------------------------------------------------------------------------------------------------------------------------------------------------------------------------------------------------------------------------------------------------------------------------------------------------------------------------------------------------------------------------------------------------------------------------------------------------------------------------------------------------------------------------------------------------------------------------------------------------------------------------------------------------------------------------------------------------------------------------------------------------------------------------------------------------------------------------------------------------|--------------------------------------------------------------------------------------------------------------------------------------------------------------------------------------------------------------------------------------------------------------------------------------------------------------------------------------------------------------------------------------------------------------------------------------------------------------------------------------------------------------------------------------------------------------------------------------------------------------------------------------------------------------------------------------------------------------------------------------------------------------------------------------------------------------------------------------------------------------------------------------------------------------------------------------------------------------------------------------------------------------------------------------------------------------------------------------------------------------------------------------------------------------------------------------------------------------------------------------------------------------------------------------------------------------------------------------------------------------------------------------------------------------------------------------------------------------------------------------------------------------------------------------------------------------------------------------------------------------------------------------------------------------------------------------------------------------------------------------------------------------------------------------------------------------|
| <p>b) durch neue Gesetze oder Verordnungen, oder durch die Auslegung eines Gesetzes oder einer Verordnung, wird der Emittent verpflichtet, Lizenzen, Zulassungen oder Genehmigungen einzuholen oder sich in irgendeiner Weise in der Bundesrepublik Deutschland oder anderswo einer Regulierung oder Überwachung zu unterstellen, um seine Verpflichtungen gemäß diesen Token-Bedingungen zu erfüllen;</p> <p>c) als Folge von Änderungen oder Ergänzungen der Gesetze oder Verordnungen der Bundesrepublik Deutschland oder eines anderen Mitgliedstaats des Europäischen Wirtschaftsraums oder deren Gebietskörperschaften oder Steuerbehörden, die die Besteuerung betreffen oder sich darauf auswirken, verändert sich die steuerliche Behandlung der tokenbasierten Schuldverschreibungen, der Token, des Underlyings oder des Emittenten wesentlich oder es fallen sonstige Abgaben an, und die Änderung bzw. Ergänzung war am Ersten Begebungstag vernünftigerweise nicht vorhersehbar und diese Änderung bzw. Ergänzung ist nach Einschätzung des Emittenten als wesentlich nachteilig für das Geschäft des Emittenten zu bewerten (ungeachtet, ob dies die Emission der tokenbasierten Schuldverschreibungen beeinträchtigt);</p> <p>d) als Folge von Änderungen oder Ergänzungen der Gesetze oder Verordnungen der Bundesrepublik Deutschland oder eines anderen Mitgliedstaats des Europäischen Wirtschaftsraums oder deren Gebietskörperschaften übersteigen die Kosten, die dem Emittenten aus oder im Zusammenhang mit den tokenbasierten Schuldverschreibungen entstehen, wesentlich die Kosten, die der Emittent zum Zeitpunkt der Ersten Begebung der tokenbasierten Schuldverschreibungen vernünftigerweise erwartet hat und erwarten durfte,</p> <p>e) ein Drittanbieter, insbesondere der Wirtschaftsprüfer, der Rechtsberater, die Zahlstelle oder der Sicherheitentreuhänder des Emittenten, stellt seine Dienstleistungen gegenüber dem Emittenten ein und dem Emittenten gelingt es nicht, innerhalb eines</p> | <p>EUR [●] on the basis of the respective Cash Euro Equivalent;</p> <p>b) by reason of any new law or regulation, or by reason of the interpretation of any law or regulation, the Issuer shall be required to obtain any licence, approval or authorisation or be subject to regulation or supervision in any manner in the Federal Republic of Germany or elsewhere in order to perform its obligations under these Token Conditions;</p> <p>c) as a result of changes or amendments to the laws or regulations of the Federal Republic of Germany or another Member State of the European Economic Area or their local authorities or tax authorities affecting or having an effect on taxation, the tax treatment of the Tokenized Securities, the Tokens, the Underlying or the Issuer changes materially or other levies are imposed and the change or amendment was not reasonably foreseeable on the First Issue Date and such change or amendment is, in the opinion of the Issuer, materially detrimental to the Issuer's business (irrespective of whether it affects the issue of the Tokenized Securities);</p> <p>d) as a result of changes or amendments to the laws or regulations of the Federal Republic of Germany or another Member State of the European Economic Area or their local authorities, the costs incurred by the Issuer arising out of or in connection with the Tokenized Securities materially exceed the costs reasonably and legitimately expected by the Issuer at the time of the initial issue of the Tokenized Securities,</p> <p>e) a third party provider, in particular the issuer's auditor, legal advisor, Paying Agent or Security Trustee, ceases to provide services to the Issuer and the Issuer fails to find a replacement within a reasonable time;</p> |
|----------------------------------------------------------------------------------------------------------------------------------------------------------------------------------------------------------------------------------------------------------------------------------------------------------------------------------------------------------------------------------------------------------------------------------------------------------------------------------------------------------------------------------------------------------------------------------------------------------------------------------------------------------------------------------------------------------------------------------------------------------------------------------------------------------------------------------------------------------------------------------------------------------------------------------------------------------------------------------------------------------------------------------------------------------------------------------------------------------------------------------------------------------------------------------------------------------------------------------------------------------------------------------------------------------------------------------------------------------------------------------------------------------------------------------------------------------------------------------------------------------------------------------------------------------------------------------------------------------------------------------------------------------------------------------------------------------------------------------------------------------------------------------------------------------------------------------------------------------------------------------------------------------------------------------------------------------------------------------------------------------------------------------------|--------------------------------------------------------------------------------------------------------------------------------------------------------------------------------------------------------------------------------------------------------------------------------------------------------------------------------------------------------------------------------------------------------------------------------------------------------------------------------------------------------------------------------------------------------------------------------------------------------------------------------------------------------------------------------------------------------------------------------------------------------------------------------------------------------------------------------------------------------------------------------------------------------------------------------------------------------------------------------------------------------------------------------------------------------------------------------------------------------------------------------------------------------------------------------------------------------------------------------------------------------------------------------------------------------------------------------------------------------------------------------------------------------------------------------------------------------------------------------------------------------------------------------------------------------------------------------------------------------------------------------------------------------------------------------------------------------------------------------------------------------------------------------------------------------------|

angemessenen Zeitraums einen Ersatz zu finden;

- |                                                                                                                                                                                                                                                                                                                                                                                                   |                                                                                                                                                                                                                                                                                                                                                                              |
|---------------------------------------------------------------------------------------------------------------------------------------------------------------------------------------------------------------------------------------------------------------------------------------------------------------------------------------------------------------------------------------------------|------------------------------------------------------------------------------------------------------------------------------------------------------------------------------------------------------------------------------------------------------------------------------------------------------------------------------------------------------------------------------|
| f) die Blockchain wird gekündigt oder stellt ganz oder teilweise die für die Übertragung der Token notwendigen Leistungen ein oder unterstützt diese nicht mehr und dem Emittenten gelingt es nicht, innerhalb eines angemessenen Zeitraums einen Ersatz zu finden;                                                                                                                               | f) the Blockchain is terminated or ceases to provide or support, in whole or in part, the services necessary for the transfer of the Tokens and the Issuer fails to find a replacement within a reasonable period of time;                                                                                                                                                   |
| g) die Verpflichtungen des Emittenten aus und im Zusammenhang mit diesen Token-Bedingungen werden nach Ansicht und Ermessen des Emittenten unangemessen belastend oder unerfüllbar;                                                                                                                                                                                                               | g) the Issuer's obligations under and in connection with these Token Conditions become, in the issuer's opinion and discretion, unreasonably burdensome or can no longer be met;                                                                                                                                                                                             |
| h) aufgrund von Umständen außerhalb des Einflusses des Emittenten verändern sich Form oder Merkmale oder die rechtlichen oder wirtschaftlichen Rahmenbedingungen des Underlyings wesentlich oder drohen sich wesentlich zu verändern, droht ein Ausfall in Bezug auf das Underlying oder ist bereits eingetreten oder hört das Underlying auf zu bestehen oder droht aufzuhören zu bestehen;      | h) due to circumstances beyond the issuer's control, the form or characteristics or the legal or economic environment of the Underlying changes materially or threatens to change materially, a default in relation to the Underlying is imminent or has already occurred or the Underlying ceases or threatens to cease to exist;                                           |
| i) aufgrund höherer Gewalt wird die Erfüllung der Verpflichtungen des Emittenten aus diesen Token-Bedingungen verhindert oder erheblich erschwert. Ereignisse höherer Gewalt sind insbesondere Systemausfälle, Brände, Evakuierungsmaßnahmen, Naturkatastrophen, von Menschen verursachte Katastrophen, bewaffnete Konflikte, Terrorakte, Aufruhr, Lockdowns und sonstige Arbeitsunterbrechungen; | i) due to force majeure, the performance of the issuer's obligations under these Token Conditions is prevented or made significantly more difficult. Force majeure events include, but are not limited to, system failures, fires, evacuations, natural disasters, man-made disasters, armed conflicts, acts of terrorism, riots, lockdowns and other interruptions of work; |
| j) ein zuständiges Gericht ordnet an, dass der Emittent eine Emittentenkündigung vorzunehmen hat oder der Emittent wurde anderweitig gesetzlich oder behördlich zur Vornahme einer Emittentenkündigung verpflichtet.                                                                                                                                                                              | j) a court of competent jurisdiction orders the Issuer to give an Issuer Call Redemption Notice or the issuer is otherwise required by law or regulation to give an Issuer Call Redemption Notice.                                                                                                                                                                           |

Eine Emittentenkündigung kann nur für sämtliche tokenbasierten Schuldverschreibungen gleichermaßen erfolgen. Der Emittent hat nach einer Emittentenkündigung zum Emittentenkündigung-Rückzahlungstag die Rückzahlung aller tokenbasierten Schuldverschreibungen vorzunehmen. Die Emittentenkündigungserklärung soll Informationen darüber enthalten, wie und bis wann die Gläubiger ihr Wahlrecht nach Ziffer 9.1 Satz 2 ausüben können. Übt der Gläubiger sein Wahlrecht nach Ziffer 9.1 Satz 2 nicht aus, wird der Emittent die Rückzahlung in Form einer Barrückzahlung vornehmen.

An Issuer Call may only be effected equally for all Tokenized Securities. Following an Issuer Call Redemption Notice, the Issuer shall redeem all Tokenized Securities on the Issuer Call Redemption Date. The Issuer Call Redemption Notice shall contain information on how and until when the Holders may exercise their option pursuant to section 9.1 sentence 2. If the Holder does not exercise its option pursuant to Number 9.1 sentence 2, the Issuer shall make the redemption in the form of a Cash Redemption.



Der Emittent ist berechtigt, den Tag, zu dem eine Rückzahlung infolge einer Emittentenkündigung fällig wird („**Emittentenkündigung-Rückzahlungstag**“) in der Emittentenkündigungs-erklärung festzulegen, wobei der Emittentenkündigung-Rückzahlungstag dem Berechnungstag nicht mehr als fünfzehn (15) Bankarbeitstage nachfolgen darf. Legt der Emittent den Emittentenkündigung-Rückzahlungstag nicht in der Emittentenkündigungs-erklärung fest, ist Emittentenkündigung-Rückzahlungstag der zehnte (10.) auf den Berechnungstag folgende Bankarbeitstag.

- 9.3 Jeder Gläubiger ist dazu berechtigt, jederzeit die Rückzahlung aller oder eines Teils seiner ausstehenden tokenbasierten Schuldverschreibungen gemäß Ziffer 9.1 zu verlangen, indem er dem Emittenten gemäß Ziffer 9.3 mitteilt, dass er die Rückzahlung verlangt (die „**Gläubiger-Rückzahlungsmitteilung**“). Der Gläubiger hat in der Gläubiger-Rückzahlungsmitteilung
- die Anzahl der tokenbasierten Schuldverschreibungen, deren Rückzahlung verlangt wird,
  - die Art der verlangten Rückzahlung (Barrückzahlung oder Lieferung), und
  - eine geeignete Konto- oder Depotverbindung zur Bewirkung von Barrückzahlung oder Lieferung durch den Emittenten

anzugeben, wobei im Rahmen einer Gläubiger-Rückzahlungsmitteilung nur jeweils einheitlich entweder Barrückzahlung oder Lieferung verlangt werden kann. Die Rückzahlung infolge einer Gläubiger-Rückzahlungsmitteilung ist zum Gläubiger-Rückzahlungstag fällig.

Eine Gläubiger-Rückzahlungsmitteilung ist unwiderruflich. Das Recht des Gläubigers, mittels Gläubiger-Rückzahlungsmitteilung Rückzahlung zu verlangen, besteht nicht, wenn der Emittent die tokenbasierten Schuldverschreibungen bereits zuvor gemäß Ziffer 9.2 mittels Emittentenkündigungs-erklärung gekündigt hat.

- 9.4 Der Emittent ist jederzeit berechtigt, tokenbasierte Schuldverschreibungen am Markt oder auf sonstige Weise zu erwerben und diese erworbenen tokenbasierten Schuldverschreibungen zu halten oder einzuziehen.

- 9.5 Alle tokenbasierten Schuldverschreibungen, die vom Emittenten nach Barrückzahlung oder

The Issuer shall be entitled to specify the date on which a Redemption becomes due as a result of an Issuer Call (“**Issuer Call Redemption Date**”) in the Issuer Call Redemption Notice, provided that the Issuer Call Redemption Date shall not be more than fifteen (15) Banking Days after the Calculation Date. If the Issuer does not specify the Issuer Call Redemption Date in the Issuer Call Redemption Notice, the Issuer Call Redemption Date shall be the tenth (10.) Banking Day following the Calculation Date.

- 9.3 Each Holder shall be entitled to demand Redemption of all or any part of its outstanding Tokenized Securities pursuant to Condition 9.1 at any time by giving notice to the Issuer pursuant to Condition 9.3 that it demands Redemption (the “**Holder Put Redemption Notice**”). In the Holder Put Redemption Notice the Holder shall specify

- the number of Tokenized Securities for which Redemption is requested,
- the type of Redemption requested (Cash Redemption or Delivery), and
- an appropriate account or securities account link to effect Cash Redemption or Delivery by the Issuer,

whereby in each case, within the scope of a Holder Put Redemption Notice, either Cash Redemption or Delivery can only be demanded collectively. The Redemption pursuant to a Tokenholder Put Redemption Notice shall be due on the Tokenholder Put Redemption Date.

A Tokenholder Put Redemption Notice is irrevocable. The right of the Tokenholder to demand Redemption by means of a Tokenholder Put Redemption Notice does not exist if the Issuer has already previously called the Tokenized Securities pursuant to Condition 9.2 by means of an Issuer Call Redemption Notice.

- 9.4 The Issuer may at any time acquire Tokenized Securities in the market or otherwise and hold or redeem such acquired Tokenized Securities.

- 9.5 Any Tokenized Securities redeemed by the Issuer upon Cash Redemption or Delivery or

Lieferung zurückgezahlt oder vom Emittenten gemäß Ziffer 9.4 erworben wurden, werden unverzüglich entwertet und dürfen nicht erneut ausgegeben, weiterverkauft oder anderweitig veräußert werden. Die Verpflichtungen des Emittenten in Bezug auf diese tokenbasierten Schuldverschreibungen sind erfüllt.

acquired by the Issuer pursuant to Condition 9.4 shall be immediately cancelled and may not be reissued, resold or otherwise disposed of. The obligations of the Issuer in respect of such Tokenized Securities have been satisfied.

## **10. Zahlungen**

10.1 Die Zahlung sämtlicher gemäß diesen Token-Bedingungen zahlbarer Geldbeträge, insbesondere des Ausgabepreises, Ertragsbeteiligungen gemäß Ziffer 8 und Barrückzahlungen gemäß Ziffer 9, erfolgt unter Berücksichtigung der jeweils geltenden gesetzlichen Bestimmungen ausnahmslos bargeldlos am jeweiligen Zahlungstag. Der Gläubiger kann andere Formen der Erfüllung gegen sich gelten lassen.

10.2 Der Emittent wird Zahlungen nach Ziffern 8 und 9 an die Person leisten, die am Tag vor dem jeweiligen Zahlungstag, um 24:00 Uhr, im Register als Gläubiger aufgeführt ist. Im Fall von Sammel-Wallets erfolgt die Zahlung an den entsprechenden Kryptoverwahrer als auszahlender Stelle zur Weiterleitung an die berechtigten Token-Inhaber, die sich aus dem Transaktionsregister anhand der ihnen dort zugeordneten Nutzer-IDs ergeben. Die Zahlung an den nach vorstehendem Satz 1 ausgewiesenen Gläubiger bzw. an den Kryptoverwahrer nach vorstehendem Satz 2 befreit den Emittenten in Höhe der geleisteten Zahlungen von seinen entsprechenden Verbindlichkeiten aus den tokenbasierten Schuldverschreibungen.

10.3 Sofern der Emittent eine nach Maßgabe dieser Token-Bedingungen geschuldete Zahlung unverschuldet nicht vornehmen kann, ist er nach Ablauf von 12 Monaten nach dem jeweiligen Fälligkeitstag berechtigt, den geschuldeten Geldbetrag beim Amtsgericht Frankfurt am Main zu hinterlegen. Soweit der Emittent auf das Recht zur Rücknahme der hinterlegten Beträge verzichtet, erlöschen die betreffenden Ansprüche des Gläubigers gegen den Emittenten und folglich gegen die Zahlstelle. Nach Verjährung des Anspruchs des entsprechenden Gläubigers erhält der Emittent die hinterlegten Beträge zurück.

## **10. Payments**

10.1 The payment of all monetary amounts payable under these Token Conditions, in particular of the Issue Price, Profit Participations pursuant to Condition 8 and Cash Redemptions pursuant to Condition 9, shall be made without exception on the respective Payment Date without cash, taking into account the respective applicable legal provisions. The Holder may accept other forms of fulfilment.

10.2 Pursuant to Conditions 8 and 9, the Issuer will make payments to the person listed as Tokenholder in the Register at 24:00 hours on the day before the relevant Payment Date. In the case of Collective Wallets, payment shall be made to the relevant Crypto Custodian as the disbursing agent for onward transfer to the eligible Tokenholders as identified in the Transaction Register by the user IDs assigned to them therein. The payment to the Tokenholder identified in accordance with sentence 1 above or to the Crypto Custodian in accordance with sentence 2 above shall release the Issuer from its corresponding obligations arising from the Tokenized Securities in the amount of the payments made.

10.3 If the Issuer is unable to make a payment owed under these Token Conditions through no fault of its own, it shall be entitled to deposit the amount of money owed with the local court of Frankfurt am Main after the expiry of 12 months following the respective Maturity Date. To the extent that the Issuer waives the right to redeem the deposited amounts, the relevant claims of the Holder against the Issuer and consequently against the Paying Agent shall expire. After the limitation of the claim of the relevant Holder, the Issuer shall receive the deposited amounts back.

## **11. Einbindung der Zahlstelle**

- 11.1 Zur Abwicklung von Zahlungen nach Maßgabe dieser Token-Bedingungen hat der Emittent die Zahlstelle beauftragt.
- 11.2 Der Emittent behält sich das Recht vor, jederzeit die Bestellung der Zahlstelle zu ändern oder zu beenden und eine andere oder zusätzliche Zahlstelle(n) zu bestellen. Der Emittent behält sich überdies das Recht vor, von der Bestellung einer externen Zahlstelle ganz abzusehen und sich selbst zur Zahlstelle in eigener Durchführung zu bestellen. Solche Änderungen werden von dem Emittenten unter Einhaltung einer Frist von mindestens 30 und nicht mehr als 45 Tagen gemäß Ziffer 9.2 bekannt gemacht.
- 11.3 Die Zahlstelle handelt ausschließlich als Erfüllungsgehilfe des Emittenten und übernimmt keinerlei Verpflichtungen gegenüber den Gläubigern. Ein Auftrags- oder Treuhandverhältnis zwischen einer Zahlstelle und den Gläubigern wird nicht begründet.

## **12. Steuern**

- 12.1 Alle Zahlungen, insbesondere Ertragsbeteiligungen nach Ziffer 8, erfolgen unter Abzug und Einbehaltung von Steuern, Abgaben und sonstigen Gebühren, soweit der Emittent zum Abzug und/oder zur Einbehaltung gesetzlich verpflichtet ist. Der Emittent ist nicht verpflichtet, den Gläubigern zusätzliche Beträge als Ausgleich für auf diese Weise abgezogene oder einbehaltene Beträge zu zahlen.
- 12.2 Soweit der Emittent nicht gesetzlich zum Abzug und/oder zur Einbehaltung von Steuern, Abgaben oder sonstigen Gebühren verpflichtet ist, trifft sie keinerlei Verpflichtung im Hinblick auf abgaberechtliche Verpflichtungen der Gläubiger.

## **13. Besicherung der tokenbasierten Schuldverschreibungen**

- 13.1 Die Besicherung der Ansprüche der Token-Inhaber aus den tokenbasierten Schuldverschreibungen erfolgt durch die Einräumung der

## **11. Involvement of the Paying Agent**

- 11.1 The Issuer has appointed the Paying Agent to process payments in accordance with these Token Conditions.
- 11.2 The Issuer reserves the right to change or terminate the appointment of the Paying Agent at any time and to appoint another or additional paying agent(s). The Issuer also reserves the right not to appoint an external paying agent at all and to appoint itself as Paying Agent in its own execution. Such changes shall be announced by the Issuer giving not less than 30 and not more than 45 days' notice in accordance with Condition 9.2.
- 11.3 The Paying Agent acts solely as an agent of the Issuer and does not assume any obligations towards the Holders. A contractual or fiduciary relationship between a paying agent and the Holders shall not be established.

## **12. Taxes**

- 12.1 All payments, in particular Profit Participations pursuant to Condition 8, shall be made subject to the deduction and withholding of taxes, duties and other charges to the extent that the Issuer is required by law to deduct and/or withhold such amounts. The Issuer shall not be obliged to pay additional amounts to Holders as compensation for amounts so deducted or withheld.
- 12.2 To the extent that the Issuer is not required by law to deduct and/or withhold taxes, duties or other charges, it shall have no obligation whatsoever with respect to any obligations of Holders under tax law.

## **13. Securitisation of the Tokenized Securities**

- 13.1 The securitisation of the claims of the Tokenholders under the Tokenized Securities shall be effected by the granting of the Security

Sicherheit an den Sicherheitentreuhänder, der die Sicherheit für Rechnung (im Rahmen eines echten Vertrages zu Gunsten Dritter) der Token-Inhaber nach Maßgabe eines zwischen dem Emittenten und dem Sicherheitentreuhänder abgeschlossenen Treuhandvertrages hält und verwaltet (der „**Sicherheiten-Treuhandvertrag**“).

- 13.2 Durch die Besicherung werden keine Ansprüche begründet, die selbständig neben den Ansprüchen aus den tokenbasierten Schuldverschreibungen gegen den Emittenten bestehen oder geltend gemacht werden können.
- 13.3 Der Sicherheitentreuhänder ist kein gemeinsamer Vertreter der Token-Inhaber im Sinne des Schuldverschreibungsgesetzes und er haftet nicht nach den Bestimmungen des Schuldverschreibungsgesetzes.
- 13.4 Der Sicherheitentreuhänder erhält vom Emittenten während der Laufzeit des Sicherheiten-Treuhandvertrages eine angemessene Vergütung sowie Ersatz seiner im Rahmen des Sicherheiten-Treuhandvertrags anfallenden Spesen, Gebühren und Auslagen.
- 13.5 Sollte der Sicherheiten-Treuhandvertrag zwischen dem Emittenten und dem Sicherheitentreuhänder während der Laufzeit der tokenbasierten Schuldverschreibungen vorzeitig beendet werden, ist der Emittent verpflichtet, einen neuen Sicherheitentreuhänder zu bestellen. Der Emittent wird einen Wechsel des Sicherheitentreuhänders gemäß Ziffer 9.2 bekanntmachen.

#### **14. Ausgabe weiterer tokenbasierter Schuldverschreibungen**

Der Emittent ist dazu berechtigt, jederzeit ohne Zustimmung der Gläubiger weitere tokenbasierte Schuldverschreibungen in anderer, gleicher oder ähnlicher Art und Weise zu begeben.

#### **15. Schlussbestimmungen**

- 15.1 Diese Token-Bedingungen sowie Form und Inhalt der tokenbasierten Schuldverschreibungen und alle sich daraus ergebenden Rechte und Pflichten der Gläubiger unterliegen ausschließlich dem Recht der Bundesrepublik Deutschland.

to the Security Trustee, which shall hold and manage the Security for the account (under a true contract for the benefit of third parties) of the Tokenholders in accordance with a trust agreement entered into between the Issuer and the Security Trustee (the “**Security Trust Agreement**”).

- 13.2 The securitisation does not give rise to any claims which independently exist or can be asserted against the Issuer in addition to the claims under the Tokenized Securities.
- 13.3 The Security Trustee is not a common representative of the Tokenholders within the meaning of the German Debenture Bond Act (*Schuldverschreibungsgesetz*) and it is not liable under the provisions of the German Debenture Bond Act.
- 13.4 The Security Trustee shall receive from the Issuer during the term of the Security Trust Agreement an appropriate remuneration as well as reimbursement of its expenses, fees and disbursements incurred in connection with the Security Trust Agreement.
- 13.5 If the Security Trust Agreement between the Issuer and the Security Trustee is terminated prematurely during the term of the Tokenized Securities, the Issuer is obliged to appoint a new Security Trustee. The Issuer will announce a change of the Security Trustee in accordance with Condition 9.2.

#### **14. Issue of further Tokenized Securities**

The Issuer is entitled to issue further Tokenized Securities in a different, identical or similar manner at any time without the consent of the Holders.

#### **15. Final Provisions**

- 15.1 These Token Conditions as well as the form and content of the Tokenized Securities and all rights and obligations of the Holders resulting therefrom shall be governed exclusively by the laws of the Federal Republic of Germany.

- 15.2 Bekanntmachungen und Erklärungen des Emittenten betreffend die tokenbasierten Schuldverschreibungen können über eine Kommunikationsfunktion der Plattform oder einer jeden anderen Plattform, auf der die jeweiligen Token-Inhaber registriert sind, über vertraglich eingebundene Intermediäre, z. B. Kryptoverwahrer oder sog. Authorised Participants, zur Weiterleitung an die Token-Inhaber und/oder durch Mitteilung in Textform (§ 126 b BGB) direkt an die jeweiligen Gläubiger erfolgen. Im Fall der Verwendung einer Kommunikationsfunktion einer Plattform gilt die Bekanntmachung oder Erklärung an dem auf die technisch nachweisbare Übermittlung folgenden Tag als wirksam erfolgt und dem jeweiligen Adressaten zugegangen; im Übrigen mit Zugang beim jeweiligen Token-Inhaber.
- 15.2 Announcements and declarations of the Issuer regarding the Tokenized Securities may be made via a communication function of the Platform or any other platform on which the respective Tokenholders are registered, via contractually integrated intermediaries, e.g. crypto custodians or so-called authorised participants, for forwarding to the Tokenholders and/or by notification in text form (§126b German Civil Code (BGB)) directly to the respective Holders. In the case of the use of a communication function of a Platform, the announcement or declaration shall be deemed to have been effectively made and received by the respective addressee on the day following the technically verifiable transfer; otherwise, upon receipt by the respective Tokenholder.
- Sofern und soweit gesetzlich zulässig, kann eine Bekanntmachung oder Erklärung des Emittenten betreffend die tokenbasierten Schuldverschreibungen auch im Bundesanzeiger und auf der Internetseite des Emittenten (<http://www.tradius.de>) erfolgen.
- If and to the extent permitted by law, an announcement or statement by the Issuer regarding the Tokenized Securities may also be published in the Federal Gazette and on the Issuer's website (<http://www.tradius.de>).
- Jede derartige Bekanntmachung oder Erklärung gilt am Tag nach der Veröffentlichung sowohl im Bundesanzeiger als auch auf der Internetseite des Emittenten als wirksam erfolgt und allen Gläubigern zugegangen.
- Any such announcement or declaration shall be deemed to have been validly made and received by all Holders on the day following its publication both in the Federal Gazette and on the Issuer's website.
- 15.3 Mitteilungen, die von einem Gläubiger gemacht werden, müssen in Textform gegenüber dem Emittenten erfolgen.
- 15.3 Notices given by a Holder must be given in text form to the Issuer.
- 15.4 Erfüllungsort für die Verpflichtungen aus den tokenbasierten Schuldverschreibungen ist Frankfurt am Main (Deutschland).
- 15.4 The place of performance for the obligations under the Tokenized Securities is Frankfurt am Main (Germany).
- 15.5 Ausschließlicher Gerichtsstand für alle Streitigkeiten zwischen Gläubigern und Emittent aus tokenbasierten Schuldverschreibungen ist Frankfurt am Main (Deutschland), sofern es sich bei dem Gläubiger um einen Kaufmann, eine juristische Person des öffentlichen Rechts oder ein öffentlich-rechtliches Sondervermögen handelt oder der Gläubiger keinen allgemeinen Gerichtsstand im Inland hat. Es gilt das Recht der Bundesrepublik Deutschland.
- 15.5 The exclusive place of jurisdiction for all disputes between Holders and the Issuer arising from Tokenized Securities is Frankfurt am Main (Germany), provided that the Holder is a merchant, a legal entity under public law or a special fund under public law or the Holder has no general place of jurisdiction in Germany. The law of the Federal Republic of Germany shall apply.
- 15.6 Sollten einzelne Bestimmungen dieser Token-Bedingungen insgesamt oder teilweise unwirksam sein oder werden, so wird hierdurch der übrige Inhalt und die Wirksamkeit dieser Token-Bedingungen nicht berührt.
- 15.6 Should individual provisions of these Token Conditions be or become invalid in whole or in part, this shall not affect the remaining content and validity of these Token Conditions.

\* \* \*

\* \* \*

## 14. FORM OF FINAL TERMS

**[MIFID II PRODUCT GOVERNANCE / PROFESSIONAL INVESTORS AND ECPS ONLY TARGET MARKET – Solely for the purposes of [the/each] manufacturer’s product approval process, the target market assessment in respect of the Tokenized Securities has led to the conclusion that for the Offer Jurisdictions: (i) the target market for the Tokenized Securities is eligible counterparties and professional clients only, each as defined in Directive 2014/65/EU (as amended, "MiFID II"); and (ii) all channels for distribution of the Tokenized Securities to eligible counterparties and professional clients are appropriate. Any person subsequently offering, selling or recommending the Tokenized Securities (a "distributor") should take into consideration the manufacturer[‘s/s’] target market assessment; however, a distributor subject to MiFID II is responsible for undertaking its own target market assessment in respect of the Tokenized Securities (by either adopting or refining the manufacturer[‘s/s’] target market assessment) and determining appropriate distribution channels[, subject to the distributor’s suitability and appropriateness obligations under MiFID II, as applicable].]**<sup>1</sup>

**[MIFID II PRODUCT GOVERNANCE / RETAIL INVESTORS, PROFESSIONAL INVESTORS AND ECPS TARGET MARKET – Solely for the purposes of [the/each] manufacturer’s product approval process, the target market assessment in respect of the Tokenized Securities has led to the conclusion that for the Offer Jurisdictions: (i) the target market for the Tokenized Securities is eligible counterparties, professional clients and retail clients, each as defined in Directive 2014/65/EU (as amended, "MiFID II"); EITHER<sup>2</sup> [and (ii) all channels for distribution of the Tokenized Securities are appropriate, including investment advice, portfolio management, non-advised sales and pure execution services] OR<sup>3</sup> [(ii) all channels for distribution to eligible counterparties and professional clients are appropriate; and (iii) the following channels for distribution of the Tokenized Securities to retail clients are appropriate - investment advice[,/ and] portfolio management[,/ and][non-advised sales ][and pure execution services][, subject to the distributor’s suitability and appropriateness obligations under MiFID II, as applicable]]. [Consider any negative target market]. Any person subsequently offering, selling or recommending the Tokenized Securities (a "distributor") should take into consideration the manufacturer[‘s/s’] target market assessment; however, a distributor subject to MiFID II is responsible for undertaking its own target market assessment in respect of the Tokenized Securities (by either adopting or refining the manufacturer[‘s/s’] target market assessment) and determining appropriate distribution channels[, subject to the distributor’s suitability and appropriateness obligations under MiFID II, as applicable].]**<sup>4,5</sup>

---

<sup>1</sup> Include legend in case MiFID II target market assessment in respect of the Tokenized Securities is "Professional Investors and Eligible Counterparties only."

<sup>2</sup> Include for Tokenized Securities that are not ESMA complex pursuant to the Guidelines on complex debt instruments and structured deposits (ESMA/2015/1787) (the "ESMA Guidelines").

<sup>3</sup> Include for Tokenized Securities that are ESMA complex pursuant to the ESMA Guidelines. This list may need to be amended, for example, if advised sales are deemed necessary. If there are advised sales, a determination of suitability and appropriateness will be necessary. In addition, if the Tokenized Securities constitute "complex" products, pure execution services to retail clients are not permitted without the need to make the determination of appropriateness required under Article 25(3) of MiFID II.

<sup>4</sup> If there are advised sales, a determination of suitability will be necessary.

<sup>5</sup> Include legend in case MiFID II target market assessment in respect of the Tokenized Securities is "Retail Investor Target Market."

## Final Terms

[Title of relevant Series of Tokenized Securities]  
issued pursuant to the

### Programme for the issuance of tokenized securities

dated 30 April 2024

of



### Tradias Issuance GmbH

Issue Price:

[•]

Total amount of the tokenized securities offered to the public:

[•]

Issue Date: [•]

Trade Date: [•]

Series No.: [•]

Tranche: [•]

ISIN: [•]

These final terms dated [•] (the "**Final Terms**") have been prepared for the purpose of Article 8(4) of Regulation (EU) 2017/1129. Full information on the Issuer and the offer of the Tokenized Securities is only available on the basis of the combination of the Final Terms when read together with the Base Prospectus of Tradias Issuance GmbH dated 30 April 2024, including any supplements thereto (the "**Base Prospectus**"). The Base Prospectus [and the supplement dated [insert date]] [, the supplement dated [insert date]] [and the supplement dated [insert date]] [has][have] been or will be, as the case may be, published on the website of the Issuer ([www.tradias.de](http://www.tradias.de)). A summary of the individual issue of the Tokenized Securities is annexed to these Final Terms.

Terms not otherwise defined herein shall have the meanings specified in the Terms and Conditions of the Tokenized Securities as set out in the Base Prospectus (the "**Terms and Conditions**").

**PART I.: TERMS AND CONDITIONS**  
**TEIL I.: EMISSIONSBEDINGUNGEN**

*[Insert completed Terms and Conditions]*

*[Ausgefüllte Emissionsbedingungen einfügen]*



**PART II.  
TEIL II.**

- |    |                                                                                                                                                           |                                                                                                                                                                                                                                                                                                                                         |
|----|-----------------------------------------------------------------------------------------------------------------------------------------------------------|-----------------------------------------------------------------------------------------------------------------------------------------------------------------------------------------------------------------------------------------------------------------------------------------------------------------------------------------|
| a) | Net proceeds and estimated total expenses of the issue/offer:                                                                                             | The net proceeds for each Tokenized Security are [●]. The estimated total expenses of the issue/offer are [●].                                                                                                                                                                                                                          |
| b) | Interest of natural and legal persons involved in the issue/offer:                                                                                        | [None] <i>[give details of any interest, including conflicting ones, that is material to the issue/offer, detailing the persons involved and the nature of the interest]</i>                                                                                                                                                            |
| c) | Reasons for the offer and use of proceeds                                                                                                                 | [●]                                                                                                                                                                                                                                                                                                                                     |
| d) | Post-Issuance Information:                                                                                                                                | [The Issuer does not intend to provide post-issuance information unless required by any applicable laws and/or regulations.][ <i>specify</i> ]                                                                                                                                                                                          |
| e) | Non-exempt Offer:                                                                                                                                         | [Not applicable] [An offer of the Tokenized Securities may be made other than pursuant to Article 1(4) of the Prospectus Regulation in the Offer Jurisdictions (as defined below) from [●] to [●] (the “Offer Period”).]                                                                                                                |
| f) | Offer Jurisdictions:                                                                                                                                      | [Not applicable] [Austria] [Belgium, [Bulgaria] [Croatia] [Cyprus] [the Czech Republic] [Denmark] [Estonia] [Finland] [France] [Greece] [Hungary] [Iceland] [Ireland] [Italy] [Latvia] [Liechtenstein] [Lithuania] [Luxembourg] [Malta] [The Netherlands] [Norway] [Poland] [Portugal] [Romania] [Slovakia] [Slovenia] [Spain] [Sweden] |
| g) | [Consent to the use of the Base Prospectus:                                                                                                               |                                                                                                                                                                                                                                                                                                                                         |
|    | The Issuer consents to the use of the Base Prospectus by the following financial intermediar[y][ies] (individual consent):                                | [Not applicable] [●]                                                                                                                                                                                                                                                                                                                    |
|    | Individual consent for the subsequent resale or final placement of the Tokenized Securities by the financial intermediar[y][ies] is given in relation to: | [Not applicable] [●]                                                                                                                                                                                                                                                                                                                    |
|    | Any other clear and objective conditions attached to the consent which are relevant for the use of the Base Prospectus:                                   | [Not applicable] [●]                                                                                                                                                                                                                                                                                                                    |
|    | The subsequent resale or final placement of Tokenized Securities by financial intermediaries can be made:                                                 | [Not applicable] [As long as the Base Prospectus is valid for the offer of the Tokenized Securities: [●]] [●] [During the Offer Period (see e) above)]                                                                                                                                                                                  |
| h) | (i) Commissions and Fees:                                                                                                                                 | [None][ <i>specify</i> ]                                                                                                                                                                                                                                                                                                                |
|    | (ii) Expenses and taxes specifically charged to the subscriber of the Tokenized Securities:                                                               | [None][ <i>specify</i> ]                                                                                                                                                                                                                                                                                                                |
| i) | Categories of potential investors:                                                                                                                        | [Retail investors] [and] [Professional investors] [and] [eligible Counterparties]                                                                                                                                                                                                                                                       |

- j) Information with regard to the manner, place and date of the publication of the results of the offer: [Not Applicable] *[if applicable, give details with regard to the manner and date in which results of the offer are to be made public]*
- k) [Name and address of the entities which have a firm commitment to act as intermediaries in secondary trading, providing liquidity through bid and offer rates and description of the main terms of their commitment (*Market Makers*): [•] *[Insert description of the main terms of commitment]*
- l) An indication where information about the past and the future performance of the underlying and its volatility can be obtained: [•]
- m) Material information with regard to the underlying: *[include brief description of the investment objectives, the risk and return profile of the investment and performance scenarios, to the extent available]*

*[Issue-specific summary to be attached]*

## **15. TAXATION**

*PROSPECTIVE PURCHASERS OF THE TOKENIZED SECURITIES ARE ADVISED TO CONSULT THEIR OWN TAX ADVISORS AS TO THE TAX CONSEQUENCES OF THE PURCHASE, OWNERSHIP AND DISPOSITION OF TOKENIZED SECURITIES, INCLUDING THE EFFECT OF ANY STATE OR LOCAL TAXES, UNDER THE TAX LAWS OF GERMANY AND EACH COUNTRY OF WHICH THEY ARE RESIDENTS. THE RESPECTIVE RELEVANT TAX LEGISLATION MAY HAVE AN IMPACT ON THE INCOME RECEIVED FROM THE TOKENIZED SECURITIES.*

## 16. SUBSCRIPTION, SALE AND OFFER OF THE TOKENIZED SECURITIES

### 16.1 OFFER OF THE TOKENIZED SECURITIES

#### a) Offer to the public

Each issue of a Series of Tokenized Securities is only purchased by Authorised Participants via the Platform operated by Tradias and will be offered by financial intermediaries to institutional and retail investors, in compliance with applicable selling restrictions during the relevant offer period (as specified in the relevant Final Terms). An offer to the public may be made in the countries specified under "Consent to the Use of the Base Prospectus".

As of the date of this Base Prospectus, the Issuer has entered into one agreement with 1 Authorised Participant.

The following Authorised Participant has been appointed as of the date of this Base Prospectus\*:

Name (regulatory status)	Address	Description
Bankhaus Scheich Wertpapierspezialist AG	Roßmarkt 21, 60311 Frankfurt am Main, Germany	BHS is an investment firm, licensed pursuant to section 15 para. 1 Investment Firm Act ( <i>Wertpapierinstitutsgesetz</i> - "WpIG") and supervised by BaFin. BHS is authorised, inter alia, to provide investment and acquisition brokerage services pursuant to section 2 para. 2 no. 3 and no. 5 WpIG, proprietary trading pursuant to section 2 para. 2 no. 10 WpIG, financial commission business pursuant to section 2 para. 2 no. 1 WpIG, placement business pursuant to section 2 para. 2 no. 8 WpIG and proprietary trading pursuant to section 15 para. 3 WpIG.

\*Any changes to the list of Authorised Participants will be detailed at [www.tradius.de](http://www.tradius.de)

#### b) Diagram on the subscription of Tokenized Securities

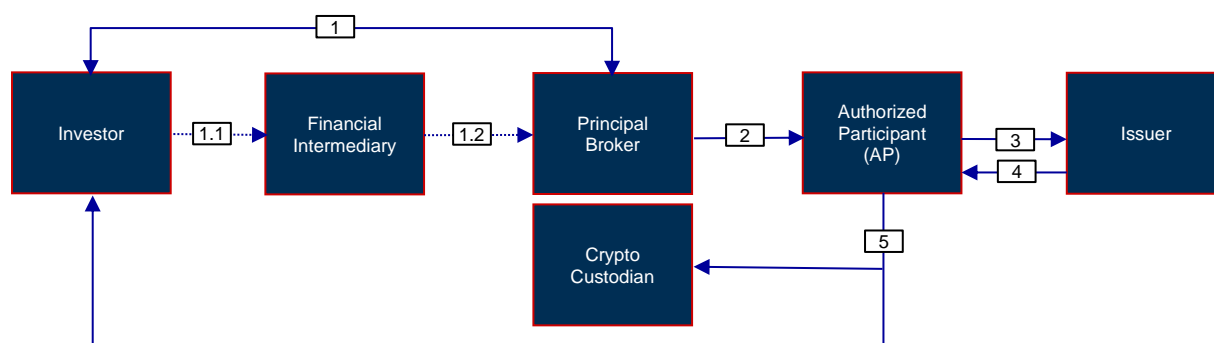

1.1 Any offer of the Tokenized Securities will be made by financial intermediaries providing investment brokerage services pursuant to section 1 para 1a sentence 2 no. 1 KWG (*Anlagevermittlung*).

1.2 If an investor decides to purchase Tokenized Securities, then the financial intermediary will transmit the order received from an investor to the principal broker (*Finanzkommissionär*) who will purchase the Tokenized Securities from the Authorized Participant in its own name but for the account of a third party pursuant to section 1 para 1 no. 4 KWG (*Finanzkommissionsgeschäft*).

2. The principal broker transmits the order to the Authorised Participant.
3. The Authorised Participant purchases the relevant number of token from the Issuer. The token will only be generated by the Issuer upon the placement of an order by the Authorised Participant with the Issuer.
4. Any delivery of token from the Issuer (to the Crypto Custodian) will be effected against payment of the Authorised Participant to the Issuer either in cash or through delivery of the relevant number of Underlyings.
5. The Issuer will then deliver the relevant number of Tokenized Securities either directly to the relevant investor or directly to the Crypto Custodian who will hold the Tokenized Securities in custody on behalf of the relevant investor.

**c) Conditions and technical details of the offer**

Any offer of Tokenized Securities is not subject to any conditions or time limits other than the time limits resulting from the validity of the Base Prospectus and the relevant offer period as specified above under "*Offer to the Public*". There is no possibility to reduce subscriptions. No minimum or maximum subscription amounts will be specified.

In the primary market, the Issuer will sell Tokenized Securities only to Authorised Participants. Tokenized Securities of any Series will only be issued upon request, i.e. such Tokenized Securities will only be purchased from the Issuer by an Authorised Participant once such Authorised Participant has received an order from a principal broker.

**d) Charges and costs relating to the offer**

The estimated total expenses of the issue and/or offer of each Series of Tokenized Securities will be specified in the relevant Final Terms of each issue of Tokenized Securities ("*Net proceeds and estimated total expenses of the issue/offer*").

**e) Method of determination of the Issue Price**

The Issue Price of the Tokenized Securities will be determined in the Final Terms.

For investors other than Authorised Participants, the purchase price for a Series of Tokenized Securities will be determined by each Authorised Participant on an ongoing basis and may be subject to additional subscription fees.

For a determination of the issue price see also *Section 13.2 – Description of the Tokenized Securities*.

## 16.2 SELLING RESTRICTIONS

### a) General

Any person subsequently offering, selling or recommending the Tokenized Securities shall comply with all applicable laws and regulations in each country or jurisdiction in which it purchases, offers, sells or delivers Tokenized Securities or possesses, distributes or publishes this Base Prospectus or any other offering material relating to the Tokenized Securities.

Persons into whose hands this Base Prospectus comes are required by the Issuer to comply with all applicable laws and regulations in each country or jurisdiction in which they purchase, offer, sell or deliver Tokenized Securities or possess, distribute or publish this Base Prospectus or any other offering material relating to the Tokenized Securities, in all cases at their own expense.

### b) European Economic Area

If the Final Terms in respect of any Series of Tokenized Securities include a legend in the context of any prohibition to make an offer of Tokenized Securities to retail investors in certain jurisdictions in the European Economic Area, the Tokenized Securities are not intended to be offered and shall not be offered to any retail investor in such jurisdiction(s). For the purposes of this provision:

- (i) the expression "retail investor" means a person who is one (or more) of the following:
  - (1) a retail client as defined in point (11) of Article 4(1) of Directive 2014/65/EU (as amended, "**MiFID II**"); or
  - (2) a customer within the meaning of Directive (EU) 2016/97 (the "**Insurance Distribution Directive**"), where that customer would not qualify as a professional client as defined in point (10) of Article 4(1) of MiFID II; or
  - (3) not a qualified investor as defined in Regulation (EU) 2017/1129 (the "**Prospectus Regulation**"); and
- (ii) the expression an "**offer**" includes the communication in any form and by any means of sufficient information on the terms of the offer and the Tokenized Securities to be offered so as to enable an investor to decide to purchase or subscribe for the Tokenized Securities.

If the Final Terms in respect of any Tokenized Securities do not include a legend in the context of any prohibition to make an offer of Tokenized Securities to retail investors in certain jurisdictions in the European Economic Area (each a "**Member State**"), any relevant person has represented that it has not made and will not make an offer of Tokenized Securities which are the subject of the offering contemplated by this Prospectus as completed by the final terms in relation thereto to the public in that Member State except that it may make an offer of such Tokenized Securities to the public in that Member State:

- (1) if the final terms in relation to the Tokenized Securities specify that an offer of those Tokenized Securities may be made other than pursuant to Article 1(4) of the Prospectus Regulation in that Member State (a "**Non-exempt Offer**"), following the date of publication of a prospectus in relation to such Tokenized Securities which has been approved by the competent authority in that Member State or, where appropriate, approved in another Member State and notified to the competent authority in that Member State, provided that any such prospectus has subsequently been completed by the final terms contemplating such Non-exempt Offer, in accordance with the Prospectus Regulation, in the period beginning and ending on the dates specified in such prospectus or final terms, as applicable, and the Issuer

has consented in writing to its use for the purpose of that Non-exempt Offer;

- (2) at any time to any legal entity which is a qualified investor as defined in the Prospectus Regulation;
- (3) at any time to fewer than 150 natural or legal persons (other than qualified investors as defined in the Prospectus Regulation) subject to obtaining the prior consent of the relevant dealer or dealers nominated by the Issuer for any such offer; or
- (4) at any time in any other circumstances falling within Article 1(4) of the Prospectus Regulation,

provided that no such offer of Tokenized Securities referred to in (2) to (4) above shall require the Issuer to publish a prospectus pursuant to Article 3 of the Prospectus Regulation or supplement a prospectus pursuant to Article 23 of the Prospectus Regulation.

For the purposes of this provision the expression an "**offer of Tokenized Securities to the public**" in relation to any Tokenized Securities in any Member State means the communication in any form and by any means of sufficient information on the terms of the offer and the Tokenized Securities to be offered so as to enable an investor to decide to purchase or subscribe for the Tokenized Securities and the expression "**Prospectus Regulation**" means Regulation (EU) 2017/1129.

#### c) **United Kingdom - Retail selling restrictions**

If the Final Terms in respect of any Series of Tokenized Securities include a legend in the context of any prohibition to make an offer of Tokenized Securities to retail investors in the United Kingdom, the Tokenized Securities are not intended to be offered and shall not be offered to any retail investor in the United Kingdom. For the purposes of this provision:

- (i) the expression "retail investor" means a person who is one (or more) of the following:
  - (1) a retail client as defined in point (8) of Article 2(1) of Commission Delegated Regulation (EU) 2017/565 as it forms part of English law by virtue of the European Union (Withdrawal) Act 2018, as amended by the Markets in Financial Instruments (Amendment) (EU Exit) Regulations 2018; or
  - (2) a customer within the meaning of Article 68(1) of the Financial Services and Markets Act 2000 (Regulated Activities) Order 2001, where that customer would not qualify as a professional client as defined in point (8) of Article 2(28) of Regulation (EU) No 600/2014 as it forms part of English law by virtue of the European Union (Withdrawal) Act 2018, as amended by the Markets in Financial Instruments (Amendment) (EU Exit) Regulations 2018; or
  - (3) not a qualified investor as defined in Regulation (EU) 2017/1129 as it forms part of English law by virtue of the European Union (Withdrawal) Act 2018 (the "**UK Prospectus Regulation**"); and
- (ii) the expression an **offer** includes the communication in any form and by any means of sufficient information on the terms of the offer and the Tokenized Securities to be offered so as to enable an investor to decide to purchase or subscribe for the Tokenized Securities.

If the Final Terms in respect of any Tokenized Securities do not include a legend in the context of any prohibition to make an offer of Tokenized Securities to retail investors in the United Kingdom, any relevant person has represented that it has not made and will not make an offer of Tokenized Securities which are the subject of the offering contemplated by this Base Prospectus as completed by the final

terms in relation thereto to the public in the United Kingdom except that it may make an offer of such Tokenized Securities to the public in the United Kingdom:

- (1) if the final terms in relation to the Tokenized Securities specify that an offer of those Tokenized Securities may be made other than pursuant to Article 1(4) of the UK Prospectus Regulation in the United Kingdom (a "**Non-exempt Offer**"), following the date of publication of a prospectus in relation to such Tokenized Securities which has been approved by the Financial Conduct Authority provided that any such prospectus has subsequently been completed by final terms contemplating such Non-exempt Offer, in accordance with the UK Prospectus Regulation, in the period beginning and ending on the dates specified in such prospectus or final terms, as applicable, and the Issuer has consented in writing to its use for the purpose of that Non-exempt Offer;
- (2) at any time to any legal entity which is a qualified investor as defined in the UK Prospectus Regulation;
- (3) at any time to fewer than 150 natural or legal persons (other than qualified investors as defined in the UK Prospectus Regulation) subject to obtaining the prior consent of the relevant dealer or dealers nominated by the Issuer for any such offer; or
- (4) at any time in any other circumstances falling within Article 1(4) of the UK Prospectus Regulation,

provided that no such offer of Tokenized Securities referred to in (2) to (4) above shall require the Issuer to publish a prospectus pursuant to Article 3 of the UK Prospectus Regulation or supplement a prospectus pursuant to Article 23 of the UK Prospectus Regulation.

For the purposes of this provision the expression "**offer of Tokenized Securities to the public**" in relation to any Tokenized Securities in the United Kingdom means the communication in any form and by any means of sufficient information on the terms of the offer and the Tokenized Securities to be offered so as to enable an investor to decide to purchase or subscribe for the Tokenized Securities.

**d) United Kingdom - Other regulatory restrictions**

Any person subsequently offering, selling or recommending the Tokenized Securities has to ensure that:

- (i) it has only communicated or caused to be communicated and will only communicate or cause to be communicated an invitation or inducement to engage in investment activity (within the meaning of Section 21 of the FSMA) received by it in connection with the issue or sale of the Tokenized Securities in circumstances in which Section 21(1) of the FSMA does not apply to the Issuer; and
- (ii) it has complied and will comply with all applicable provisions of the FSMA with respect to anything done by it in relation to the Tokenized Securities in, from or otherwise involving the United Kingdom.

**e) United States**

The Tokenized Securities have not been and will not be registered under the U.S. Securities Act of 1933, as amended (the "**Securities Act**"), and may not be offered, sold or delivered within the United States of America (the "**United States**") to or for the account or benefit of, U.S. persons except pursuant to an exemption from, or in a transaction not subject to, the registration requirements of the Securities Act. Accordingly, the Tokenized Securities are being offered and sold only (1) to "accredited investors" (as defined in Rule 501 of Regulation D under the Securities Act) in compliance with Rule 506(c) or Rule 506(b) of Regulation D under the Securities Act; (2) to 'qualified institutional buyers' as defined in Rule 144A under the Securities Act; and (3) in "offshore transactions" (as defined in Regulation S



under the Securities Act) in reliance upon Regulation S under the Securities Act. Any person acting as a distributor of the Tokenized Securities exclusively outside the United States has represented and agreed that neither it nor any persons acting on its behalf has offered, sold or delivered or will offer, sell or deliver any Tokenized Securities within the United States except in accordance with Rule 903 of Regulation S under the Securities Act. Accordingly, each such distributor has represented and agreed that neither it, its affiliates nor any persons acting on its or their behalf has engaged or will engage in any directed selling efforts with respect to the Tokenized Securities offered in reliance on Regulation S. Terms used in this subparagraph have the meaning given to them by Regulation S.

## 17. GENERAL INFORMATION

### 17.1 INCORPORATION BY REFERENCE

The following information is incorporated by reference into this Base Prospectus:

<b>Information incorporated by reference</b>	<b>Pages incorporated by reference</b>	<b>Page in Base Prospectus</b>
----------------------------------------------	----------------------------------------	--------------------------------

#### Financial Information

(A) Audited annual financial statements of the Issuer (*Jahresabschluss*) dated 31 December 2022 together with an unqualified auditor's report

Balance Sheet	Annex ( <i>Anlage</i> ) I	21
Profit and Loss Statement	Annex ( <i>Anlage</i> ) II	21
Notes	Annex ( <i>Anlage</i> ) III	21
Cash Flow Statement	Annex ( <i>Anlage</i> ) IV	21
Unqualified Auditor's Report	Annex ( <i>Anlage</i> ) V	21

(B) Audited annual financial statements of the Issuer (*Jahresabschluss*) dated 31 December 2023 together with an unqualified auditor's report

Balance Sheet	Annex ( <i>Anhang</i> ) 1	21
Profit and Loss Statement	Annex ( <i>Anhang</i> ) 2	21
Notes	Annex ( <i>Anhang</i> ) 3	21
Cash Flow Statement	Annex ( <i>Anhang</i> ) 4	21
Unqualified Auditor's Report	Annex ( <i>Anhang</i> ) 5	21

The information incorporated by reference can be found on the following websites:

- The audited annual financial statements of the Issuer (*Jahresabschluss*) dated 31 December 2022 together with an unqualified auditor's report:
- <https://www.tradias.de/wp-content/uploads/2024/03/PB-JA-2022-Tradias-Issuance-GmbH.pdf>
- The audited annual financial statements of the Issuer (*Jahresabschluss*) dated 31 December 2023 together with an unqualified auditor's report:
- <https://www.tradias.de/wp-content/uploads/2024/03/tradias-Issuance-GmbH-Jahresabschluss-2023.pdf>

All pages of the documents incorporated by reference set out above shall be deemed to be incorporated by reference in, and to form part of, this Base Prospectus.

Any information not incorporated by reference into this Base Prospectus but contained in the documents set out above as source documents in the cross-reference list above is either not relevant for investors or covered elsewhere in this Base Prospectus.

The documents containing the information incorporated by reference have been filed with BaFin. They are available free of charge by the Issuer and are published in electronic form on the Issuer's website [www.tradius.de](http://www.tradius.de).

## 17.2 DOCUMENTS ON DISPLAY

For the term of this Base Prospectus, copies of the following documents will be available on the website of the Issuer (<https://www.tradius.de/impressum>):

- (i) the Base Prospectus and any supplement thereto;
- (ii) the constitutional documents of the Issuer;
- (iii) the Terms and Conditions;
- (iv) the Security Trust Agreement in relation to each Series of Tokenized Securities;
- (v) the relevant Final Terms for each Series of Tokenized Securities; and
- (vi) the documents incorporated by reference.

## **18. NAMES AND ADDRESSES**

### **ISSUER**

**Tradias Issuance GmbH**  
Roßmarkt 21  
60311 Frankfurt am Main  
Germany

### **SECURITY TRUSTEE**

**Tradias Treuhandgesellschaft mbH**  
Roßmarkt 21  
60311 Frankfurt am Main  
Germany

### **AUDITORS**

**D & P Wirtschaftsprüfung GmbH**  
Biebergasse 2  
60313 Frankfurt am Main  
Germany